

# Heat Recovery & Mechanical Chimney Draught

- for Industrial & Commercial Applications



# THE SYSTEM

## HEAT RECOVERY

By installing an **exodraft** heat recovery system, excess heat from flue gasses, steam or process air can be converted into hot water to be used for a variety of useful purposes as opposed to simply going to waste.

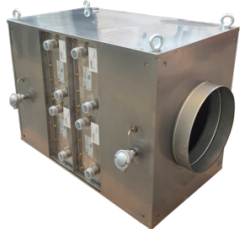

Basic Plate (BP) Series

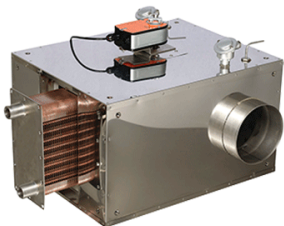

Safe Plate (SP) Series

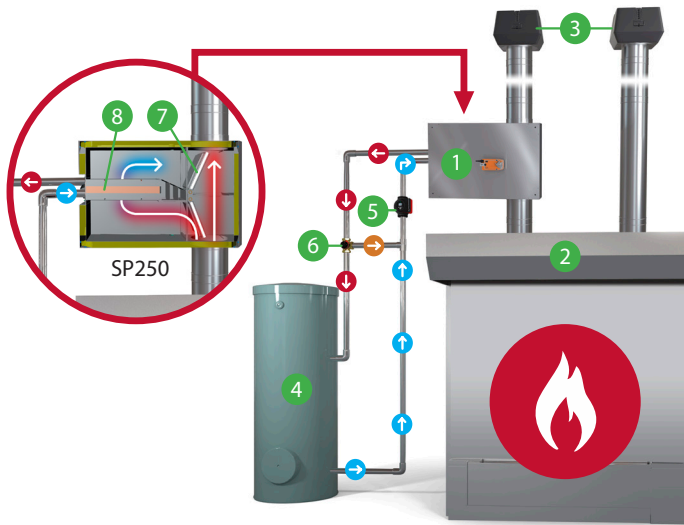

- 1 Safe 250 heat recovery unit
- 2 Heat-generating process, e.g. boiler, engine, oven, dryer
- 3 **exodraft** chimney fan which ensures an optimal draught and perfect production results
- 4 Buffer tank to store hot water for later use
- 5 Circulation pump
- 6 3-way mixer valve which ensures correct temperature of the water
- 7 Integrated bypass damper
- 8 Compact heat exchanger

By enabling the conversion of flue gasses, steam or hot process air from your production processes into hot water, the basis is created for capitalising on substantial amounts of waste heat, in turn saving you money, reducing CO<sub>2</sub> emissions and helping the environment. What is more, a heat recovery system from **exodraft** can be installed without affecting the uptime of your production.

Where to use the recovered energy:

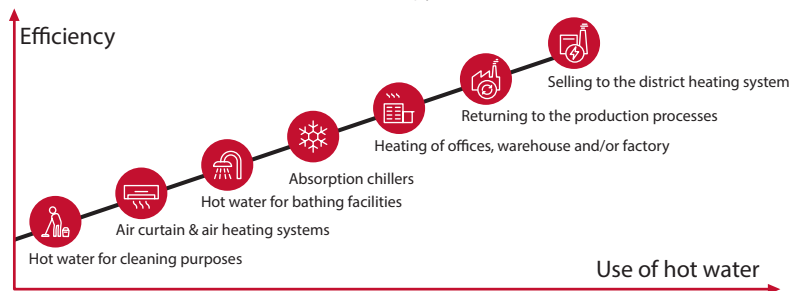

## MECHANICAL CHIMNEY DRAUGHT

Changes in atmospheric pressure, outside temperature and wind conditions affect the chimney's ability to create updraught. If weather conditions are not optimal, the heat-generating process (e.g. oven, boiler etc.) will compensate by using more energy. This constant seesawing of changing external factors and internal compensation will invariably lead to uneven and unsatisfactory production results as well as increased energy costs.



RSV Series

RSHT Series

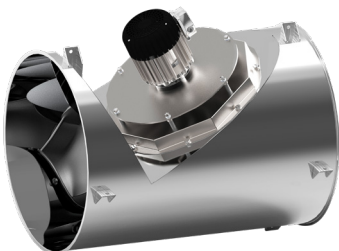

CFIR Series

Natural Chimney Draught (Pa) = = = =

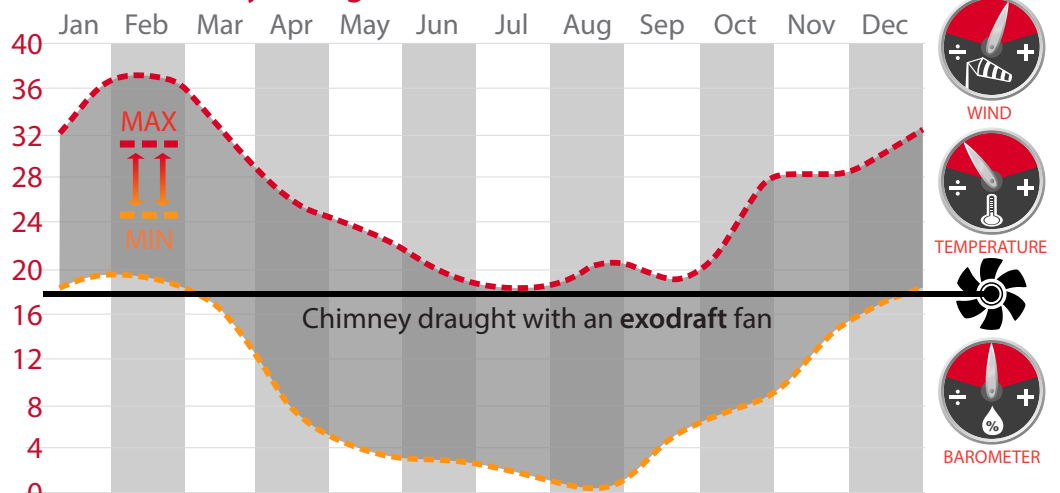

An **exodraft** chimney fan system maintains an always optimal chimney draught, regardless of external factors, ensuring consistent and controllable production conditions.

# THE SYSTEM

## Environmentally friendly is economical

With ever-increasing energy costs and stricter demands on CO<sub>2</sub> emission, it makes increasingly good sense to capitalise on the excess energy found in flue gas, steam and other process air in exhaust and extraction systems.

Many businesses within both the commercial and industrial segments have production processes which generate heat that go straight up the chimney and into the atmosphere. At **exodraft**, we are experts when it comes to helping companies recover this waste heat from flue gas, steam and process air and converting it into utility heat that save them money while benefitting the environment.

### Energy recovery levels

With an **exodraft** heat recovery solution, as much as 95% of the waste energy can be recovered. This translates to a potential 15-30 % reduction in fuel consumption and an equivalent reduction in CO<sub>2</sub> emission.

The effective heat recovery, combined with a competitive price, means that the investment in an **exodraft** heat recovery solution will often have a pay-back period around 2-3 years!

## The correct chimney draught is crucial

Modern production processes require full control of all factors influencing said processes. A chimney with either insufficient or too much draught can have a negative impact on the entire production and critically compromise the quality of its final output. The natural draught in a chimney is neither constant, nor controllable, and is affected by external factors such as indoor and outdoor temperature, barometric pressure changes, wind speed and wind direction – hence the need for controllable mechanical draught.

### Correct draught and heat exchangers

Because **exodraft** heat exchangers are highly efficient, capable of extracting up to 95% of the waste heat in your flue system, flue resistance will invariably increase as a result of the dropping flue temperature. To counteract this, and to create fully controllable draught conditions in your chimney, we draw on 60+ years' experience as the market leader of mechanical chimney draught to ensure that you get the best of both worlds – super efficient heat recovery *and* an always optimal chimney draught. This unique combination of know-how is ultimately what sets **exodraft** apart from other suppliers of heat recovery solutions.

## Commercial

Every single day, we assist customers within both the commercial segment as well as light and heavy industries to reduce their CO<sub>2</sub> emissions and lower their energy costs through heat recovery. We also help them achieve a consistent and controllable chimney draught for more predictable production results.



Large kitchens



Wood fired pizza ovens



Oil- og gas boilers



Restaurants



Small bakeries



Barbeque / Grill

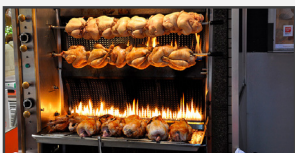

Streetfood



Pubs/Bars

## Industrial



Surface treatment



Glass production



Industrial bakeries



Heat treatment plants



Can manufacturing



Meat refinement



Industrial coffee roasteries



Aluminium production

# INSTALLATION EXAMPLES

## HEAT RECOVERY

A heat recovery system from **exodraft** can be installed on the existing chimney or in a separate chimney configuration as shown below. Owing to a bypass system, installed either separately (BD series) or as an integrated part of the heat recovery unit (SP series), excess heat from flue gasses, steam or process air can be turned into hot water without influencing production uptime.

- 1 **exodraft** BP500 heat recovery unit
- 2 **exodraft** CFIR inline fan
- 3 **exodraft** RSV chimney fan
- 4 **exodraft** bypass damper BD350 (single chimney)
- 5 **exodraft** bypass damper BD350 (separate chimneys)

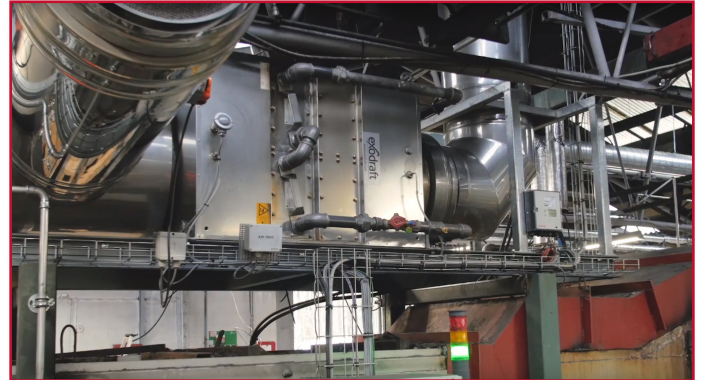
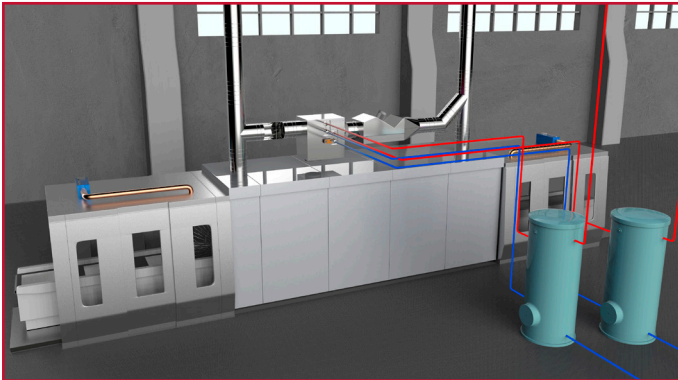
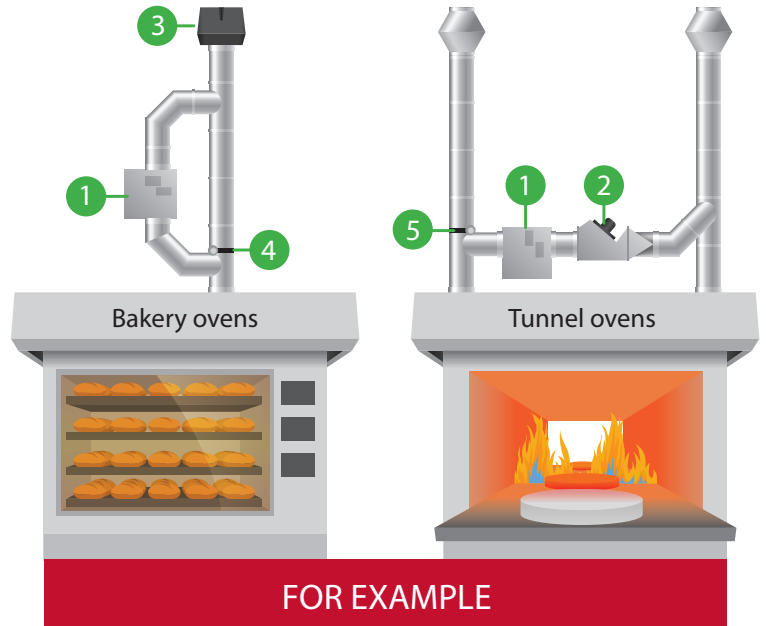

## MECHANICAL CHIMNEY DRAUGHT

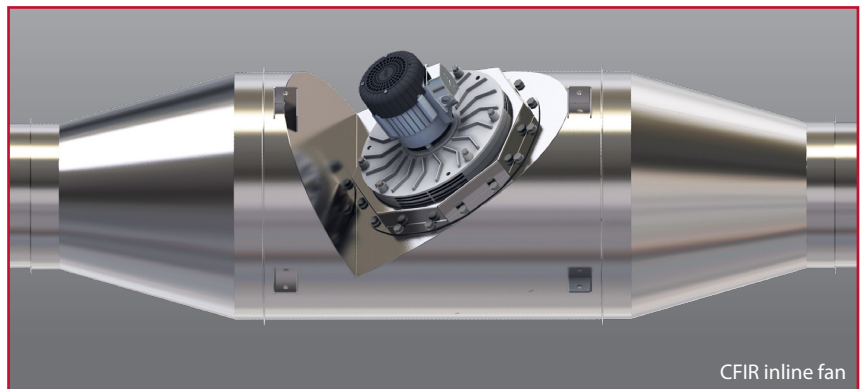

A mechanical draught system from **exodraft** consists of a chimney fan installed at the discharge point of the chimney or an inline fan installed in your duct. The optimum system for your needs is calculated using **exodraft's** proprietary calculation software. This guarantees a perfect match between our solution and your requirements.

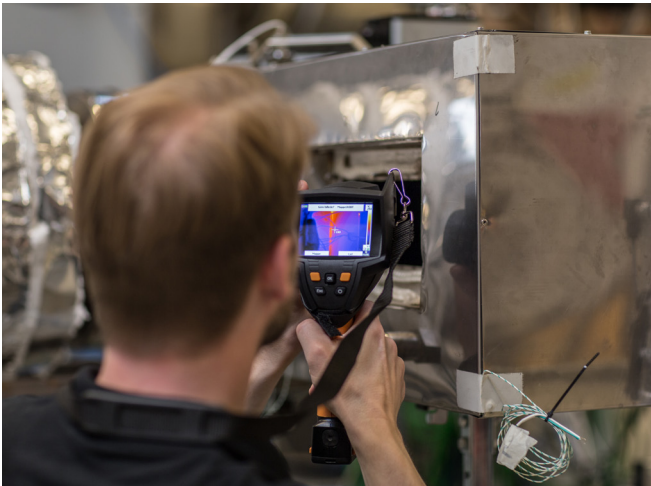

## Pre-Analysis

Our engineers carry out:

- Chimney draught analysis
- Heat recovery analysis
- Data logging



## exodraft OptiCalcHR™

Using our exodraft OptiCalcHR™ software, we can calculate how much energy can be recovered, how much money you can save as well as your reduction in CO<sub>2</sub> emission. Get in touch with us today and let us calculate your heat recovery and savings potential.

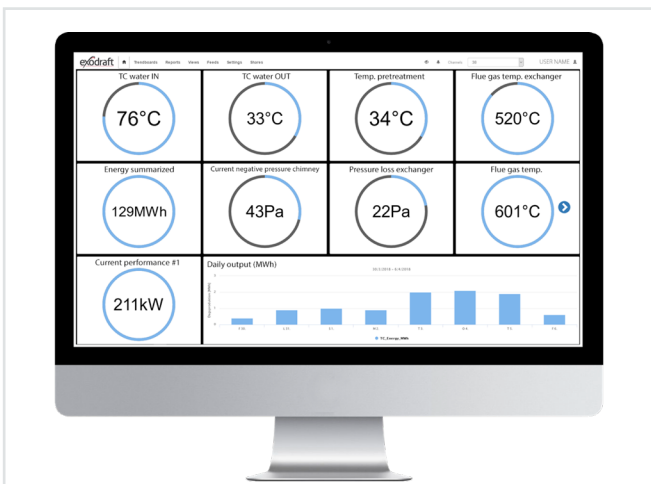

## exodraft Trendlog

With the exodraft Trendlog, you can monitor your energy savings and overall heat recovery performance online in real-time. Trendlog data can also be used to analyse errors and find optimisation options on your system.



## After Sales

We offer different services even after your heat recovery solution has been installed. These services include staff training, check-ups and technical support.

# CASE STORIES

## HEAT RECOVERY



### KVERNELAND – DENMARK



Japanese-owned Kverneland Group was faced with considerable amounts of waste heat from their hardening plant in Kerteminde, Denmark. However, after installing a heat recovery system from **exodraft**, they are now able to recover up to 80% of this waste heat, some of which they transfer directly and automatically to the local district heating system in exchange for money, providing a new income stream while at the same time aiding the local community. Another added benefit of the heat recovery system is that the indoor climate of the factory has improved significantly with the removal of foul-smelling odours, much to the delight of its many workers.



Watch full case video here:  
[exodraft.co.uk/kverneland](http://exodraft.co.uk/kverneland)



### DOT – DENMARK



DOT is known for complete solutions for surface treatment and corrosion protection of metal. They mainly do hot-dip galvanization, submerging steel elements into hot, molten zinc in order to protect the steel against corrosion. They had so much waste heat from their molten zinc pots, which they used to simply vent to the outdoors. After installing an **exodraft** heat recovery system, they use the recovered energy to heat up liquids in their pre-treatment facility as well as heating up the metal elements before they go into the zinc. This prevents the zinc from flying and reduces overall zinc consumption. Also, because the elements are dry instead of wet when they go into the zinc, DOT has reduced their build-up of ash significantly.

“*exodraft has really been more of a collaborative partner as opposed to just a supplier.*”

Poul-Erik Roed-Christensen  
Plant Manager, DOT



Watch full case video here:  
[exodraft.co.uk/dot](http://exodraft.co.uk/dot)



### STAEHLE – GERMANY



G. Staehe GmbH is one of the top three European manufacturers of aerosol cans and prides itself on sustainability and environmental awareness. The process of printing on the thin aluminum plates that the aerosol cans are subsequently made of results in gasses, which are passed through a 600-degree thermal post-combustion which renders them safe to release into the environment. This is why, during the planning stage of a new printing line in Schifferstadt, Staehe took flue gas heat recovery into account. According to Staehe CEO, Marc Oliver Staehe, the reason that Staehe chose **exodraft** as the supplier, was that they were able to offer the most compact and efficient heat recovery unit on the market along with the chimney system as a complete turn-key solution. Since October 2016, Staehe has been using the recovered heat to heat their 7,500 m<sup>2</sup> warehouse, keeping their heating costs at a minimum.



Watch full case video here:  
[exodraft.co.uk/staehe](http://exodraft.co.uk/staehe)

# CASE STORIES

MECHANICAL CHIMNEY DRAUGHT



## AAFES BAKERY – GERMANY



Aafe Bakery is part of a large catering company, which each day provides thousands of workers in the southwestern part of Germany with bakery products. For that reason, it is crucial that the company is able to reliably deliver its baked goods every day without exception. As part of a renovation of the bakery, Aafe Bakery decided to upgrade its facilities with the latest technology. This included, among other things, two **exodraft** RSV250 chimney fans installed in conjunction with an automatic control unit, also from **exodraft**.

Bakery ovens rarely function optimally with the use of a conventional chimney system and by relying solely on natural draught as they are, then, at the mercy of external factors such as outside temperature and weather. By installing a mechanical draught system from **exodraft**, Aafe Bakery was able to ensure a consistent and controllable draught in their oven-connected chimneys, further ensuring an always consistent and predictable bakery product, regardless of external factors beyond its control.



## BURJ KHALIFA – DUBAI



Mixed-use tower featuring world's first Armani Hotel Dubai and Armani Residences, alongside corporate suites, residences, retail and leisure facilities. A 500-acre mega-development by Emaar Properties. At 2,716 ft. (828 m), it's the world's tallest structure.

Six demand-controlled **exodraft** (sold by **ENERVEX, USA**) inline mechanical draught systems was provided for the building's water heaters and steam boilers. The six chimney flues connected to these heating appliances run mostly horizontally through the building, terminating to the outside via sidewalls or through the ground for aesthetics. The draught system also provides ventilation to the mechanical room by maintaining an air exhaust rate while controlling the chimney flue draught, as well as the combustion air intake.



## WOOD – NORWAY



In a shopping mall in Trondheim, Norway, a new pizza restaurant recently opened its doors to paying customers. The name of the pizzeria is **WOOD** – and its owner, Adrian Løvold, has specialised in baking pizzas using a wood-fired pizza oven. The oven uses a combination of wood and gas which means that the temperature can reach up to 400 degrees celcius, allowing it to bake a delicious and crispy pizza in just a few minutes. Like all other wood- and gas-fired installations, the oven is dependent on a chimney. However, with the restaurant located in the middle of a shopping mall, building the right chimney for the job was no small task as the chimney had to stretch no less than 60 meters, sporting an impressive 13 bends along the way. The only way to make this intricate installation work was to install an **exodraft** chimney fan type RSV at the discharge point of the chimney.



Watch full case video here:  
[exodraft.co.uk/wood](https://exodraft.co.uk/wood)

# OUR PRODUCTS

## HEAT RECOVERY

### BASIC PLATE (BP) 250-2000

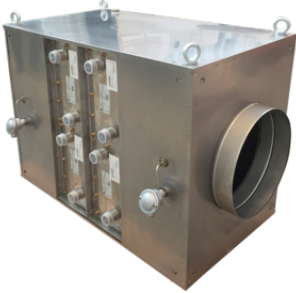

- Maximum flue gas temperature of 600°C on air side
- Can be combined with other Basic Plate units in a modular fashion for higher flue gas volumes
- All parts in connection with flue gas made of stainless steel 316 (EN 1.4404)
- All external parts made of stainless steel 304 (EN 1.4301)
- 40 mm insulation
- Designed for indoor use, but can be used outdoors if the product is covered/encapsulated

### SAFE PLATE (SP) 80-500

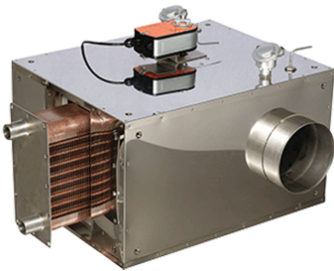

- Maximum flue gas temperature of 400°C on air side
- Integrated bypass protects the system from overheating
- All parts in connection with flue gas made of stainless steel 316 (EN 1.4404)
- All external parts made of stainless steel 304 (EN 1.4301)
- 40 mm insulation
- Maximum pressure water side of heat exchangers is 12 bar
- Designed for indoor use, but can be used outdoors if the product is covered/encapsulated

### EAHC21 (PLC) CONTROL



- Input and output for 2 heat recovery units and 2 buffer tanks
- Remote access via web server
- Easy installation
- Expandable I/O capacity
- Multiple bus compatible (BACnet, MODBUS/IP, KNX, PROFIBUS)
- 24-230 V AC/DC startup signal
- Integrated touch display with user-friendly interface
- 3 standard motor configuration options



The Basic Series can be supplied as a stand-alone or modular system

### Benefits of choosing an **exodraft** heat recovery system

- Quick return on investment – usually 2-3 years
- Most compact and lightweight heat recovery system on the market
- Easy maintenance due to removable heat exchangers
- Our bypass system ensures stable and continuous operation (no production downtime)
- A single dedicated contact person to ensure the best customer service experience
- PLC control allows for both onsite and remote control and monitoring (optional)
- Can be installed both vertically and horizontally
- Very short delivery time – normally 4-5 weeks



# OUR PRODUCTS

HEAT RECOVERY

## DAMPER MOTOR (DM) 350-500



- Used for the protection or control of hot flue gas flow to BP units
  - Max. flue gas temperature 600 °C
  - Parts in contact with flue gas are stainless steel EN 1.4404
  - All exterior parts are made from stainless steel EN 1.4301
  - Only for indoor installation
- (installation outside requires extra shielding)
- An integrated electric motor opens and closes the flue. Two types: on/off or modulating motor

## BYPASS DAMPER (BD) 250-500



- Used to control flue gas / process heat flow to BP units
  - Max flue gas temperature 600 °C
  - An integrated electric motor opens and closes the damper
  - Parts in contact with flue gas are stainless steel EN 1.4404
  - All exterior parts are made from stainless steel EN 1.4301
- Only for indoor installation (installation outside requires extra shielding)
  - Bypass damper has a safety spring return, causing it to close automatically in case of a power failure

## EHC20 - CONTROL



- The EHC20 control monitors the heat exchanger, the mixing valve, the circulation pump and the buffer tank, including the flue gas sensor, contact sensor and the two storage sensors
  - For standalone systems controlled only on site
- SD card slot with 2GB SD
  - Start-up assistant for easy step-by-step setup
  - Alarm output relay

**SECOND-TO-NONE COMPACTNESS:**  
OUR SIZE-EFFECT RATIO IS A **GAME-CHANGER** IN THE INDUSTRY

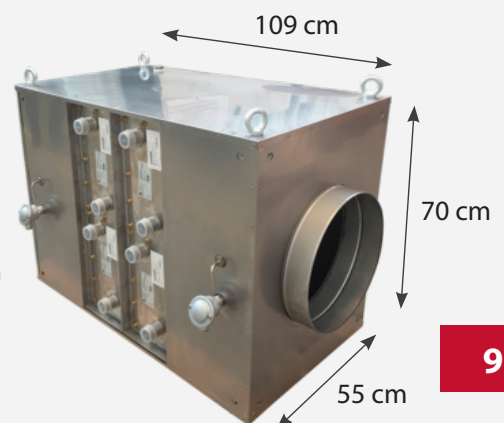
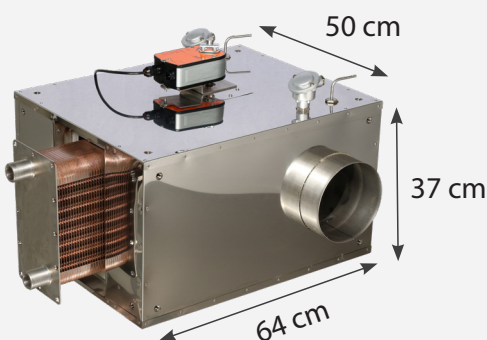

# OUR PRODUCTS

MECHANICAL CHIMNEY DRAUGHT

## CFIR 300/400/500 INLINE FAN

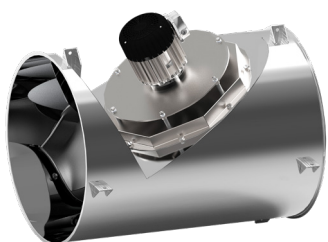

- Max. flue gas temperature 600 °C
- Compact, cylindrical design
- High-efficiency aluminium centrifugal impeller with variable speed
- Can be installed both horizontally and vertically in your duct system
- Stable construction designed to handle pulsating boilers
- Stainless steel construction in accordance with EN1.4404(316L) for indoor and outdoor installation
- Designed to meet EN16475 demands for gas seal

## RSV 009-450



- The **exodraft** chimney fan RSV is an exhaust fan with a vertical discharge
- The fan is placed on top of the chimney, creating a vacuum in the chimney flue
- RSV is suitable for all kinds of solid fuel but is especially ideal for wood-fired fireplaces, boilers, and stoves
- The chimney fan is part of an **exodraft** system and must be combined with an **exodraft** control

## RSHT 009-016



- The RSHT chimney fan is designed to operate under extreme conditions with very high flue gas temperatures
- The patented cooling wheel allows continuous operation of the chimney fan at temperatures up to 500°C.
- Peak load (up to three minutes) with temperatures up to 700°C are possible with the RSHT
- The chimney fan is part of an **exodraft** system and must be combined with an **exodraft** control

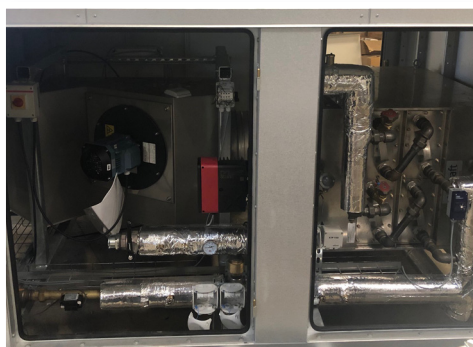

# OUR PRODUCTS

MECHANICAL CHIMNEY DRAUGHT

## EBC24 - CONTROL



- EBC24 is an automatic control with a pressure transducer (XTP) for 2 boilers or other installations with 2 heat sources (number of boilers can be expanded with ES12 relay box)
- With the help of the XTP sensor, which is installed in the chimney, the chimney draught is monitored and maintained by automatically regulating the speed of the chimney fan
- Integrated safety system shuts down heating appliances connected to the flue system in case of insufficient draught or system/power failures
- RS485 interface for MODBUS communication
- Alarm output

## EBC22 - CONTROL



- Automatic control for 2 or more gas boilers, or other installations where multiple heat sources are connected to the same chimney by automatically regulating the speed of the chimney fan
- Input and output for up to 2 boilers as standard (can be expanded with ES12 relay box)
- Easy installation
- With the help of the XTP sensors, which are installed in the chimney, the chimney draught is monitored and maintained
- Alarm output to BMS
- Kiwa Gastec-certified

## PLENUMBOX PLX 2-4



- The plenumbox can be used for multiple fans (up to 4) on one chimney for higher flue gas volumes. Made of stainless steel 1.4571, thickness 2 mm.

We can supply a fully assembled turn-key solution, ready to be lifted onto your roof and connected to your chimney extraction system\*.

\* Turn-key solutions are currently only available in Germany, UK, Denmark, Sweden, Austria, Switzerland, Luxembourg, Holland & Belgium

## Who is exodraft?

**exodraft** is a Danish company that manufactures and develops heat recovery & chimney draught systems for various industries and private users worldwide.

## A clear mission:

We want to develop and sell heat recovery systems and mechanical exhaust systems of the highest quality possible. Our systems shall recover otherwise wasted energy effectively, thereby helping to protect the environment.

## Comprehensive knowledge:

Our system solutions are built on more than 60 years of experience within chimney draught technology as well as extensive knowledge about the relationship between combustion and the draught in the chimney.

## ISO certified quality:

At **exodraft**, we constantly optimise and develop our products further. Quality and documentation are two of the cornerstones in the production of our system solutions. We are ISO9001 certified which is why we can document our high quality.



Visit our websites for more information:

[www.exodraft-heatrecovery.co.uk](http://www.exodraft-heatrecovery.co.uk)

[www.exodraft.co.uk](http://www.exodraft.co.uk)

### DK: exodraft a/s

Industrivej 10  
DK-5550 Langeskov  
Tel: +45 7010 2234  
Fax: +45 7010 2235  
info@exodraft.dk  
www.exodraft.dk

### NO: exodraft a/s

Storgaten 88  
N-3060 Svelvik  
Tel: +47 3329 7062  
info@exodraft.no  
www.exodraft.no

### DE: exodraft a/s

Niederlassung Deutschland  
Soonwaldstr. 6  
DE-55569 Monzingen  
Tel: +49 (0)6751 855 599-0  
Fax: +49 (0)6751 855 599-9  
info@exodraft.de  
www.exodraft.de

### SE: exodraft a/s

Kalendevägen 2  
SE-302 39 Halmstad  
Tlf: +46 (0)8-5000 1520  
info@exodraft.se  
www.exodraft.se

### UK: exodraft Ltd.

24 Janes Meadow, Tarleton  
GB-Preston PR4 6ND  
Tel: +44 (0)1494 465 166  
Fax: +44 (0)1494 465 163  
info@exodraft.co.uk  
www.exodraft.co.uk

### FR: exodraft sas

78, rue Paul Jozon  
F-77300 Fontainebleau  
Tel: +33 (0)6 3852 3860  
info@exodraft.fr  
www.exodraft.fr