



exodraft

Technical Data

Chimney fans, controllers & accessories

- Wood-burning stoves and fireplaces
- Multiple appliances on a header system
 - Biomass boiler
- Gas fireplaces, stoves and single non-modulating gas boilers

exodraft



Table of contents

Project and design support	3
----------------------------	---

System descriptions

Components for fireplaces or wood-burning stoves	4
Components for solid fuel or biomass-burning boilers	5
Components for gas fireplaces or gas-fired boilers	6
Components for single non-modulating gas boilers	7

Technical data

RS chimney fan	8
RSV chimney fan	10
RSHT chimney fan	12
RSHG chimney fan	14
RSVG chimney fan	16
RHG chimney fan	18
RSG chimney fan	19
Inline fan CFIR	22
Greasefan GSV	25
EFC16 & EFC35/EFC35S control	26
EFC18 control	27
Xzense control	28
EFC21 control	29
EBC10v2 control	30
EBC24 control	31
Frequency Inverter FRK	32
Cover plates	32
Flanges	33
Other fitting accessories	34
Isolation switch	34
Plenumbox PLX	34

Installing the fans, service and maintenance	35
---	-----------

Project and design support

exodraft solutions are much more than just products and systems. In close co-operation with our **exodraft** dealers worldwide we provide pre-sale analysis, system design and provide recommendations.

A customized **exodraft** design software is used. This enables us to design any system with great accuracy and makes it possible to provide the results in an advanced sizing report.

With a correct calculation from **exodraft** we take full responsibility for the system's operation. All calculations and system recommendations provided by **exodraft** are performed in accordance with the relevant rules and regulations.

exodraft and our dealers offer telephone engineering and installation support. All calculations are stored electronically for engineers and technicians to have a record of what a system looks like and includes.

To make the most accurate calculation we ask for an appraisal form on the installation.

Appraisal Form Fireplaces, Stoves and Cookers

1a Originator: _____ Telephone Mobile/Home: _____		
Company: _____ Telephone Work: _____		
Job reference: _____ Fax Number: _____		
1b Type of property (tick): Private dwelling <input type="checkbox"/> Public House/Hotel/Restaurant <input type="checkbox"/>		
2. Fuel used (tick): Wood <input type="checkbox"/> Smokeless or Coal <input type="checkbox"/> Oil <input type="checkbox"/> Natural Gas <input type="checkbox"/> LPG <input type="checkbox"/> Other _____		
3a If an open fireplace, please tick your type of fireplace		
3b Measurements		
Width of opening (a) _____ mm (____ inch)		
Height from hearth to top of opening or to Hood (h) _____ mm (____ inch)		
Depth from front of opening (b) _____ mm (____ inch)		
Depth from front of opening (c) _____ mm (____ inch)		
Height of gather/hood from top of opening to throat of chimney _____ mm (____ inch)		
3c. If gas, please state maximum gas input: _____ kW or _____ Btu		
4. If a closed appliance (tick) (& fill out measurements in 3b)		
Stove <input type="checkbox"/> Cooker <input type="checkbox"/>		
Max heat input: _____ kW or _____ Btu		
5. For a fireplace having a lintel, state the Depth (D) of the lintel _____ mm (____ ins) (Maximum (D) 100 mm)		
6. Is the THROAT in the centre of the gather? YES <input type="checkbox"/> NO <input type="checkbox"/> If no, state shortest W _____ mm (____ inch)		
7. Extract fan system in the room? YES <input type="checkbox"/> NO <input type="checkbox"/>		
8a Chimney height: _____ m or _____ ft		
Internal size _____ mm or _____ inch		
No. of bends in chimney _____ (45°) _____ (90°)		
8b Chimney shape: round <input type="checkbox"/> rectangular <input type="checkbox"/>		
8c Flue material: brick <input type="checkbox"/> metal (twin-wall) <input type="checkbox"/> flexible liner <input type="checkbox"/> stone <input type="checkbox"/> metal (single-wall) <input type="checkbox"/> clay <input type="checkbox"/> other _____		
8d Insulation: thickness _____ mm, _____ m ² /KW		
9a Is the chimney more than 40 cm higher than the ridge of the roof: YES <input type="checkbox"/> NO <input type="checkbox"/>		
9b Is the angle of the roof: <25° <input type="checkbox"/> 25°-40° <input type="checkbox"/> >40° <input type="checkbox"/>		
9c. Is the chimney closer than 20 km (12.5 mi) to the coast: YES <input type="checkbox"/> NO <input type="checkbox"/>		
9d Is the chimney close to adjacent obstructions: YES <input type="checkbox"/> NO <input type="checkbox"/> Adjacent obstructions are buildings, tall trees or mountains within a 15 m range, extending at a 30°+ horizontal angle and a 10°+ vertical angle from top of chimney.		
Dimensioned sketch of installation with flue run must be included as attachment!		
For Office Use Only _____	Pressure Loss Pa: _____	Accessories: _____
Flue Gas Temp. °C _____	Recommended Fan: _____	Calculated by: _____
Air Volume m ³ /hr: _____	Controller: _____	Date: _____
Please send filled out form to: info@exodraft.co.uk or fax: +01494 465 163		

Components for fireplaces or wood-burning stoves











With exodraft chimney fan systems you always have control over the chimney draught regardless of the weather conditions or other factors influencing the natural draught.

The function of the chimney is both to remove the smoke and supply oxygen for effective combustion. In an ideal situation this is done through the natural chimney draught, but in reality, both the chimney itself and other external factors affect the natural draught and thus the effectiveness of the chimney.

An **exodraft** chimney fan gives you complete control over the chimney draught. The chimney fan is installed on top of the chimney and creates a negative pressure in the flue, thus ensuring that the flue gases are extracted up the chimney rather than into the room. The fan control enables you to adjust the chimney draught to suit your needs, so you can enjoy the full comfort of your fireplace.

An **exodraft** chimney fan system consists of a RS or a RSV chimney fan, a fan control and some installation accessories.

Find the components you need here:

	Component	Type	Page
1	Chimney fan	 RS with horizontal exhaust	8
		 RSV with vertical exhaust	10
2	Control	 EFC16	26
		 EFC35/EFC35S	26
		 EFC18	27
		 Xzense	28
		 EBC10v2	30
3	Isolation switch	 REP-AFB	34
		 REPSW2x16	34
4	Accessories for Installation	 Flange	33

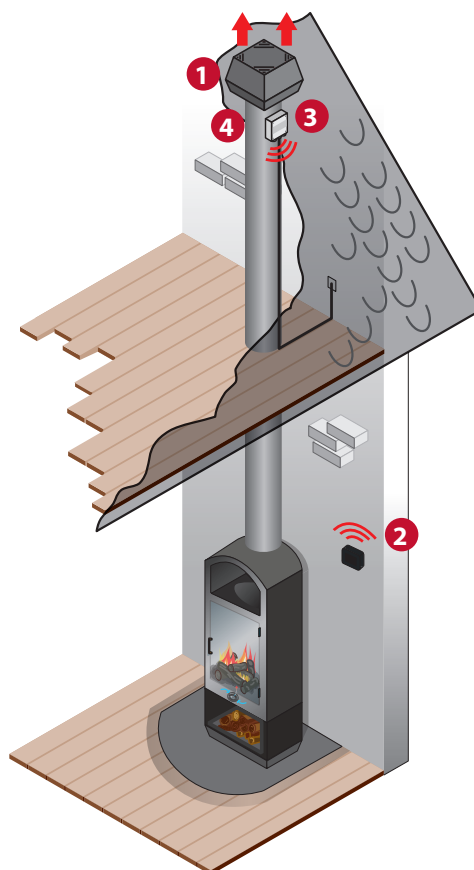

Components for solid fuel or biomass-burning boiler









A natural draught chimney system is designed to work at average conditions for the region. When a solid fuel or biomass boiler is used all year round, the variable climatic conditions will sometimes lead to insufficient chimney draught. The use of a chimney fan system will ensure the correct chimney draught under any climatic conditions at all times.

When a biomass burning appliance, for example a pellet stove, has chimney draught issues it might be a challenge lighting the fire and it may cause soot and smoke to be expelled back into the room. Insufficient chimney draught can also lead to poor combustion, and inefficient use of the fuel.

This can be solved by installing an **exodraft** chimney fan system which ensures the correct chimney draught all times.

An **exodraft** system for a solid fuel or biomass burning boiler consists of an RS or RSV chimney fan, a controller and installation accessories.

Find the components you need here:

	Component	Type	Page
1	Chimney fan	 RS with horizontal exhaust	8
		 RSV with vertical exhaust	10
2	Control	 EFC16	26
		 EFC35/EFC35S	26
		 EFC18	27
		 EBC24	31
3	Isolation switch	 REP-AFB	34
		 REPSW2x16	34
4	Accessories for Installation	 Flange	33

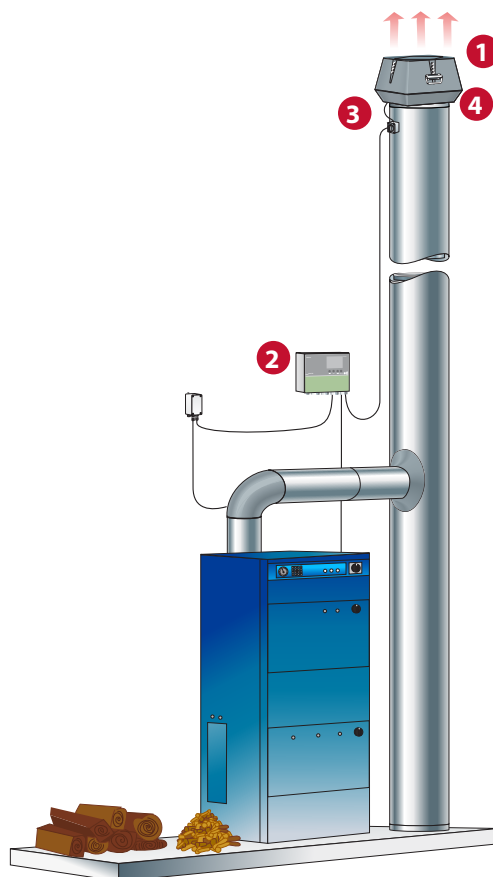

Systems for gas fireplaces and gas stoves

The **exodraft chimney fan systems for open gas fireplaces are the only ones on the market that feature an approved fail-safe function which ensures that you are not exposed to any unnecessary hazards from your open gas fire.**

The **exodraft** chimney fan system gives you the freedom to choose your gas fireplace based on what you prefer, rather than what the building architecture or layout will allow. In some countries the system can be used in conjunction with a wall-mounted chimney fan.

An **exodraft** chimney fan system for gas fireplace or stove consists of a chimney fan with a flow measuring system, a Kiwa Gastec approved fan control and installation accessories.





Four types of **exodraft** chimney fans are available for gas: RHG & RSHG, RSVG and the wall-mounted RSG. They are all fitted with a flow measurement system which –with an EFC21 control system – ensures that gas is not supplied to the fireplace unless there is sufficient draught in the chimney.

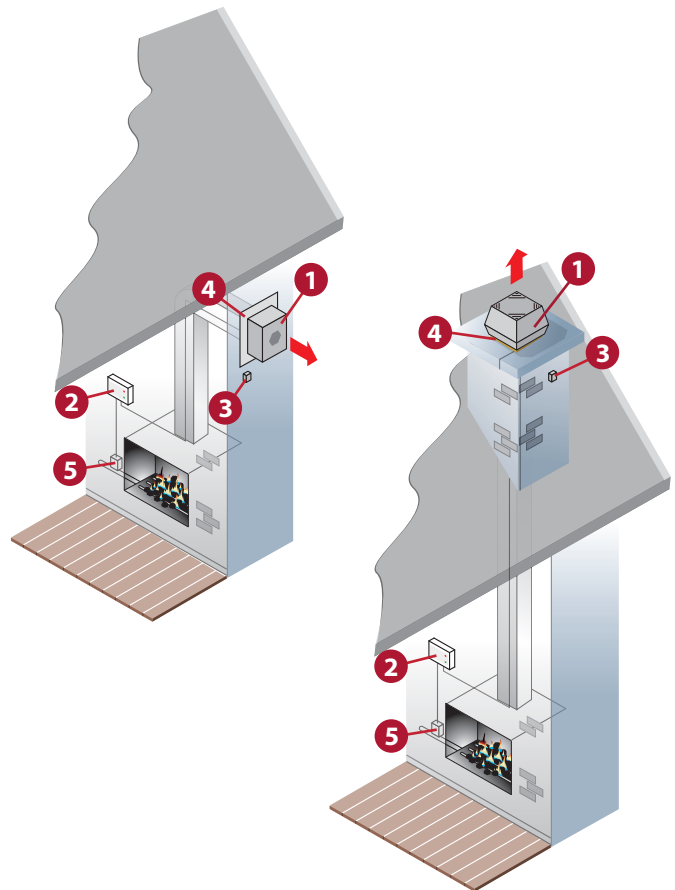





When switched on, a signal is sent to the chimney fan to create the optimal updraught in the chimney. When this is achieved, the control system opens the gas valve, allowing the fire to be lit. Any reduction in updraught will result in the gas supply to the fire being cut and the fire being switched off.

This is the only system in the market with EN298 Kiwa Gastec approval. The design of the optimum system components for the individual system is calculated using the **exodraft** design software in accordance with BS EN 13384.



Find the components you need here:

	Components	Type	Page
1	Chimney fan	 RSHG with horizontal exhaust	14
		 RSVG with vertical exhaust	16
		 RHG with horizontal exhaust	18
		 RSG wall-mounted	19

	Components	Type	Page
2	Control	 EFC21	29
		 EBC22	
3	Isolation switch	 REPSW2x16	34
4	Accessories for installation	 Flange	33
5	Solenoid valve	 SMG 12	29
		 SMG 14	

Components for single non-modulating gas boilers

The exodraft chimney fan system for single non-modulating gas boiler installations offers great possibilities within flue and chimney design. The stepless adjustable fan motor and the electronic control ensure a constant draught that guarantees combustion and better heating economy. Large savings on flue systems and installation costs are realistic as downsizing of flue diameters and chimney heights becomes possible.

An exodraft chimney fan system for a single non-modulating gas boiler consists of a chimney fan with a flow measuring system, a Kiwa Gastec approved fan control and installation accessories. It is used where there is a need for design flexibility, enhanced energy performance of the appliances or guarantee against spillage of combustion materials or carbon monoxide.





When switched on, a signal is sent to the chimney fan to create the optimal updraught in the chimney. Once this is achieved, the control system opens the gas valve, allowing the burner to be lit. Any reduction in updraught will result in the gas supply to the fire being cut and the fire being switched off.

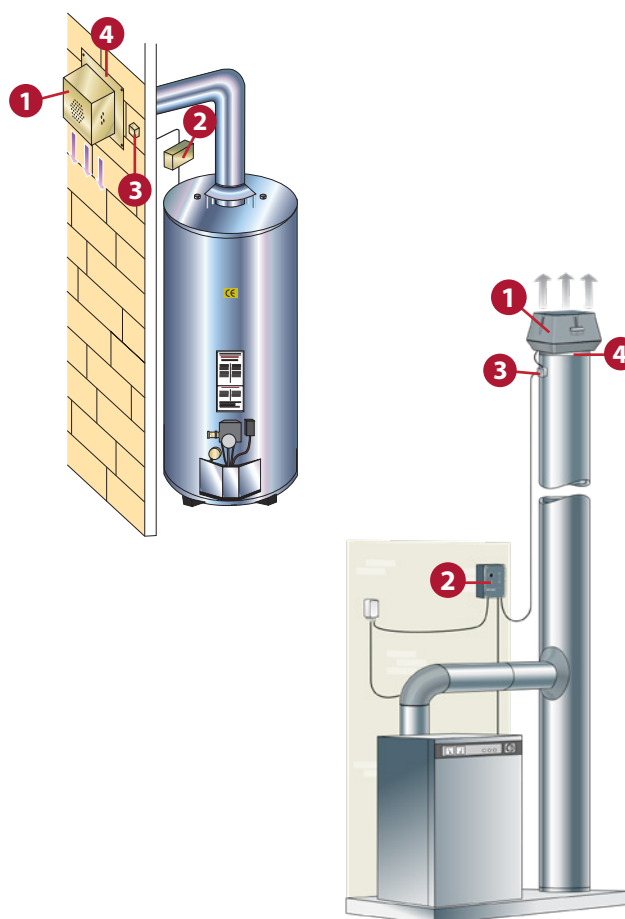



Four types of exodraft chimney fans are available for gas: RHG & RSHG, RSVG and the wall-mounted RSG. They are all fitted with a flow measurement system which – with the EFC21 control system – ensures that gas is not supplied to the boiler unless there is sufficient draught in the chimney.

This is the only system in the market that have the sought-after EN298 Kiwa Gastec approval. The design of the optimum system components for the individual system is calculated using the exodraft design software in accordance with BS EN 13384.



Find the components you need here:

	Components	Type	Page
1	Chimney fan	 RSHG with horizontal exhaust	14
		 RSVG with vertical exhaust	16
		 RHG with horizontal exhaust	18
		 RSG wall-mounted	19

	Components	Type	Page
2	Control	 EFC21	29
		 EBC22	
3	Isolation switch	 REPSW2x16	34
4	Accessories for installation	 Flange	33

RS chimney fan



Description

An **exodraft** RS chimney fan is a specially designed chimney fan with horizontal discharge.

The fans can be used with all types of fuel burning appliances and are especially well-suited to solid fuel appliances, such as wood-burning fireplaces and stoves, biomass- and solid-fuel boilers.

Design and construction

exodraft chimney fans are made to continuously withstand flue gas temperatures of up to 250 °C and

continue functioning in dirty environments. They are constructed of corrosion-resistant cast aluminum. Screws and bolts are made of stainless steel.

RS chimney fans are available in a range of sizes and capacities. The RS009, RS012, RS014 and RS016 models are equipped with stainless steel axial vanes. The chimney fan RS255 and RS285 are equipped with a centrifugal impeller with cast aluminium blades.

The RS chimney fan has a temperature resistant, entirely closed asynchronous motor, with ball bearings sealed for life. The motor is positioned away from harmful flue gases and is continuously cooled by a special cooling plate and cooling vents. The heat-resistant supply cable has cable-strain relief and is armoured.

The chimney fan opens easily, so that a chimney sweep can sweep the chimney and clean the chimney fan without any problems. A safety mesh covers the radial discharge for protection.

RS technical data

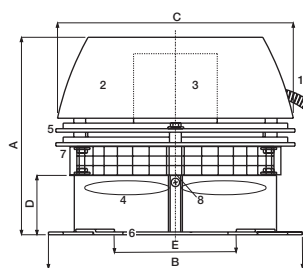

- | | |
|----------------|-------------------|
| 1. Motor cable | 5. Cooling plate |
| 2. Top section | 6. Base plate |
| 3. Motor | 7. Hinges |
| 4. Vane | 8. Locking screws |

Model	Motor data				Weight kg	Dimension (mm)				
	rpm	V	Amp	kW*		A	B	C Ø	D	E Ø
RS009-4-1	1400	1 x 230	0,3	0,05	9	250	300	285	75	220
RS012-4-1	1400	1 x 230	0,4	0,09	14	275	365	350	85	280
RS014-4-1	1400	1 x 230	0,6	0,13	18	330	420	395	100	330
RS016-4-1	1400	1 x 230	1,2	0,29	25	405	480	450	100	380
RS255-4-1	1400	1 x 230	0,4	0,07	14	260	300	350	35	200
RS285-4-1	1400	1 x 230	0,8	0,18	20	290	355	395	35	230

*Power consumption at ambient temperature of 20 °C
 The RPM of the above fan models are infinitely adjustable
 Motor protection IP rating IP54
 Insulation class F

The RS009 and RS012 fans can also be supplied with an octagonal bottom section, specially designed for circular chimneys.

RS sound data

Sound levels to external surroundings
Lw (dB) measured in accordance to ISO 3744

Model	Lw (dB)							Lp dB (A)
	125 Hz	250 Hz	500 Hz	1000 Hz	2000 Hz	4000 Hz	8000 Hz	
RS009-4-1	54	50	47	43	38	31	25	21
RS012-4-1	64	60	55	52	48	42	34	30
RS014-4-1	75	69	65	62	57	51	44	41
RS016-4-1	81	76	72	69	64	58	52	47

Tolerance +/- 3 dB.
Lw = sound effect level dB (reference: 1 pW)
Lp = sound pressure level dB (A) at 10 m distance from the fan at half spheric sound distribution
Lp (5 m) = Lp (10 m) + 6 dB
Lp (20 m) = Lp (10 m) - 6 dB

RS capacity diagram

The capacity diagram shown below is only for illustration. Contact **exodraft** or your nearest dealer to calculate the correct fan size.

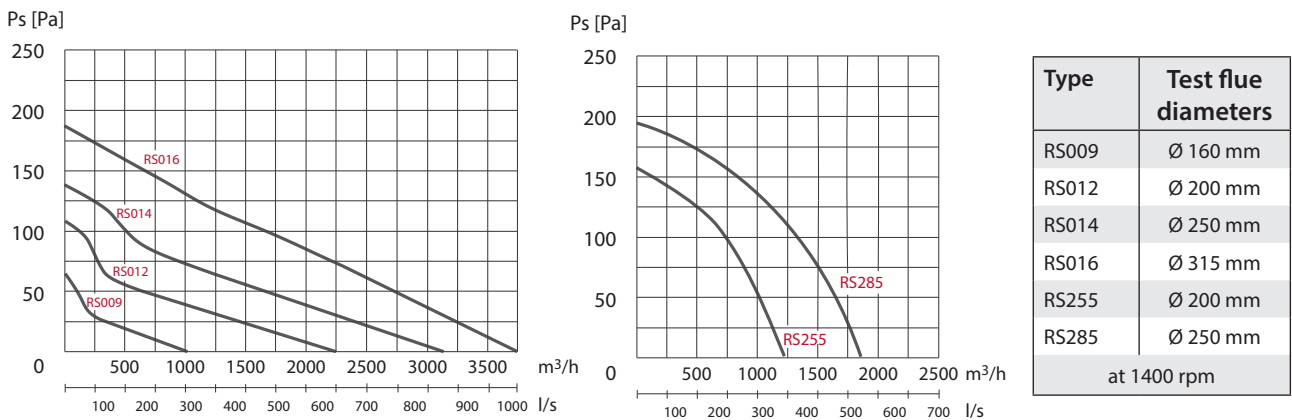

PLEASE NOTE: The capacity diagrams are measured with a flue gas temperature of 20 °C. The fan's capacity changes with the temperature of the flue gases. The correction of the capacity can be calculated using the following equation:

$$P_{s_{20}} = P_{s_t} \times \frac{273 + t}{293}$$

Ps = static pressure
t = temperature measured in °C

Example:

System demand: 500 m³/h and 90 Pa at 180 °C
Fan selection: 500 m³/h and 139 Pa at 20 °C

RSV chimney fan



Description

An **exodraft** RSV chimney fan is a specially designed chimney fan with vertical discharge.

The fans can be used with all types of fuel burning appliances and are especially well-suited to solid fuel appliances, such as wood-burning fireplaces and stoves, biomass- and solid-fuel boilers.

Design and construction

exodraft chimney fans are specially made to continuously withstand flue gas temperatures of up to 250 °C and continue functioning in dirty environments.

They are constructed of corrosion resistant cast aluminium. Screws and bolts are made of stainless steel.

The RSV009, RSV012, RSV014 and RSV016 models are equipped with axial stainless steel vanes. The RSV160, RSV200, RSV250, RSV315 and RSV400 models are equipped with a cast aluminium centrifugal impeller and are used for larger installations.

The RSV chimney fan has a temperature resistant, entirely closed asynchronous motor, with ball bearings sealed for life. The motor is positioned away from harmful flue gases and is continuously cooled by a special cooling plate and cooling vents. The heat-resistant supply cable has cable-strain relief and is armoured.

The chimney fan opens easily, so that a chimney sweep can sweep the chimney and clean the fan without any problems. The exhaust vent has a protective stainless steel grille.

RSV technical data

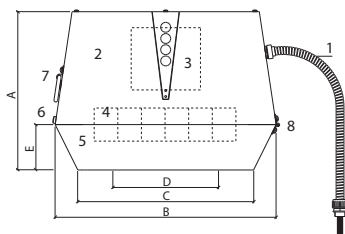

- | | |
|------------------------------|-------------------|
| 1. Connecting cable | 5. Bottom section |
| 2. Top section | 6. Locking screws |
| 3. Motor | 7. Handle |
| 4. Vane/centrifugal impeller | 8. Hinges |

Model	Motor data				Weight kg	Dimension [mm]				
	rpm	V	Amp	kW*		A	B x B	C x C	D Ø	E
RSV009-4-1	1400	1 x 230	0,14	0,05	13	250	310	240	215	70
RSV012-4-1	1400	1 x 230	0,35	0,13	17	280	390	310	275	80
RSV014-4-1	1400	1 x 230	0,8	0,16	24	335	485	385	335	100
RSV016-4-1	1400	1 x 230	1,8	0,32	35	380	580	465	365	115
RSV160-4-1	1400	1 x 230	0,4	0,04	12	250	310	240	160	70
RSV200-4-1	1400	1 x 230	0,4	0,07	18	280	390	310	200	80
RSV250-4-1	1400	1 x 230	0,8	0,16	27	335	485	385	250	100
RSV315-4-1	1400	1 x 230	1,8	0,37	37	380	580	465	315	115
RSV400-4-1	1400	1 x 230	2,6	0,60	47	430	650	525	400	130

*Power consumption at ambient temperature of 20 °C

The RPM of the above fan models are infinitely adjustable

Motor protection IP rating IP54

Insulation class F

RSV sound data

Sound levels to external surroundings
 Lw (dB) measured in accordance with ISO 3744

Model	Lw (dB)							Lp dB (A)
	125 Hz	250 Hz	500 Hz	1000 Hz	2000 Hz	4000 Hz	8000 Hz	
RSV009-4-1	57	55	54	49	40	35	26	26
RSV012-4-1	64	62	61	55	51	46	40	33
RSV014-4-1	71	70	68	61	56	50	44	40
RSV016-4-1	76	76	70	65	60	55	49	44
RSV160-4-1	56	54	57	51	44	34	28	30
RSV200-4-1	64	62	61	55	51	46	40	33
RSV250-4-1	64	68	66	65	61	49	45	41
RSV315-4-1	71	75	70	73	68	57	52	48
RSV400-4-1	76	80	75	79	74	62	57	53

Tolerance +/- 3 dB
 Lw = sound effect level dB (reference: 1 pW)
 Lp = sound pressure level dB (A) at 10 m distance from the fan at half spheric sound distribution
 Lp (5 m) = Lp (10 m) + 6 dB
 Lp (20 m) = Lp (10 m) - 6 dB

RSV capacity diagrams

The capacity diagrams shown below are only for illustration. Contact **exodraft** or your nearest dealer to calculate the correct fan size.

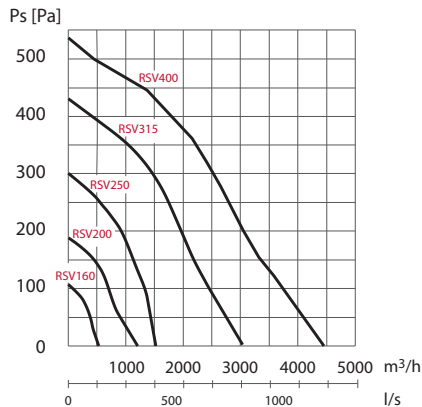
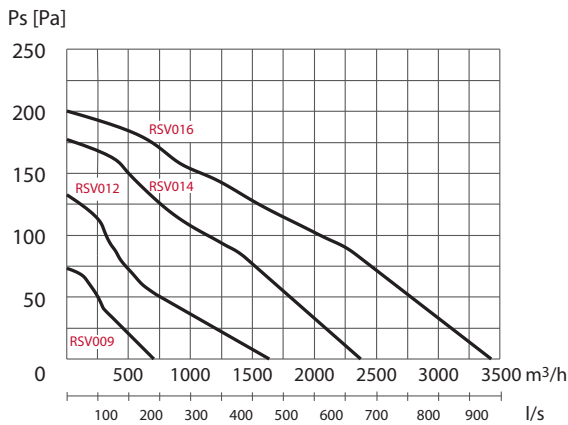

Type	Test flue diameters
RSV009	ø 160 mm
RSV012	ø 200 mm
RSV014	ø 250 mm
RSV016	ø 315 mm
RSV160	ø 160mm
RSV200	ø 200 mm
RSV250	ø 250 mm
RSV315	ø 315 mm
RSV400	ø 400 mm

at 1400 rpm

PLEASE NOTE: The capacity diagrams are measured with a flue gas temperature of 20 °C. The fan's capacity changes with the temperature of the flue gases. The correction of the capacity can be calculated using the following equation:

$$Ps_{20} = Ps_t \times \frac{273 + t}{293}$$

Ps = static pressure
 t = temperature measured in °C

Example:

System demand: 500 m³/h and 90 Pa at 180 °C
 Fan selection: 500 m³/h and 139 Pa at 20 °C

RSHT chimney fan



Description

The **exodraft** RSHT chimney fan is designed to operate under extreme conditions with very high flue gas temperatures.

The patented cooling wheel allows continuous operation of the chimney fan at temperatures up to 500 °C. Peak loads (up to 30 minutes) with temperatures up to 700 °C are possible with the RSHT.

Design and construction

The RSHT has a horizontal discharge and is made of stainless steel with an aluminium housing. The chimney fan is equipped with a stainless steel axial impeller. Screws and bolts are also made of stainless steel.

The engine is a heat-resistant asynchronous motor in an enclosed construction with sealed, maintenance-free ball bearings that is continuously adjustable with a TRIAC control.

The cable is heat-resistant and strain relieved, and protected by a reinforced hose casing.

The chimney fan is hinged, which gives the chimney sweeper easy access to sweep the chimney.

A protective stainless steel grille is installed to prevent contact and stop birds from entering the chimney.

RSHT technical data

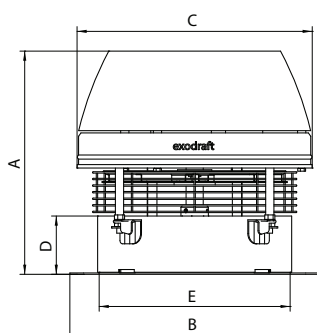

Model	Motor data				Weight kg	Dimension [mm]				
	rpm	V	Amp	kW*		A	B	C ø	D	E ø
RSHT009-4-1	1400	1 x 230	0,4	0,09	12	298	296	275	75	220
RSHT012-4-1	1400	1 x 230	0,6	0,13	15	325	364	344	85	280
RSHT014-4-1	1400	1 x 230	1,2	0,29	19	372	422	395	100	330
RSHT016-4-1	1400	1 x 230	1,8	0,37	22	400	478	441	100	380

* Power absorbed with an ambient temperature of 20 °C

The rotational speed of the flue gas fan is steplessly variable on all single phase 230 V versions.

Protection rating IP 54, Insulation class F

RSHT sound data

Sound levels to external surroundings
 Lw (dB) measured in accordance with ISO 3744

Model	Lw (dLw (dB))							Lp dB (A)
	125 Hz	250 Hz	500 Hz	1000 Hz	2000 Hz	4000 Hz	8000 Hz	
RSHT009-4-1	66	61	63	57	58	57	51	37
RSHT012-4-1	72	74	71	65	66	62	54	33
RSHT014-4-1	80	76	72	70	71	68	61	49
RSHT016-4-1	84	81	75	74	73	70	65	52

Tolerance +/- 3 dB
 Lw = sound effect level dB (reference: 1 pW)
 Lp = sound pressure level dB (A) at 10 m distance from the fan at half spheric sound distribution
 Lp (5 m) = Lp (10 m) + 6 dB
 Lp (20 m) = Lp (10 m) - 6 dB

RSHT capacity diagrams

The capacity diagrams shown below are only for illustration. Contact **exodraft** or your nearest dealer to calculate the correct fan size.

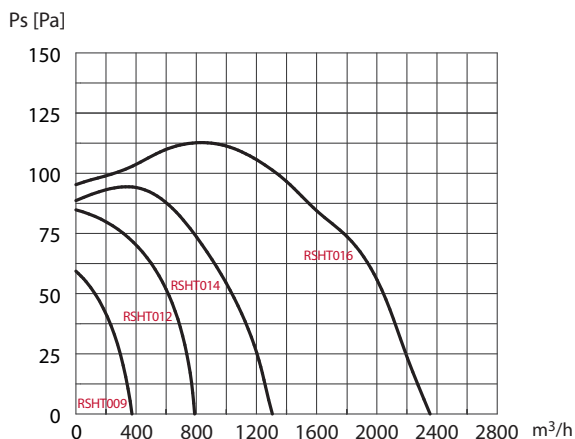

PLEASE NOTE: The capacity diagrams are measured with a flue gas temperature of 20 °C. The fan's capacity changes with the temperature of the flue gases. The correction of the capacity can be calculated using the following equation:

$$P_{s_{20}} = P_{s_t} \times \frac{273 + t}{293}$$

P_s = static pressure
 t = temperature measured in °C

Example:
 System demand: 600 m³/h and 32 Pa at 180 °C
 Fan selection: 600 m³/h and 50 Pa at 20 °C

RSHG chimney fan



Description

An **exodraft** chimney fan RSHG is specially designed to work with heating appliances burning gas.

The RSHG fans guarantee optimum draught irrespective of the placement, dimensions or height of the chimney which is beneficial to new or existing installations.

The fan must be connected to an **exodraft** EFC21 control.

Design and construction

The chimney fan has a horizontal discharge and an

integrated monitoring system, consisting of a pressure control switch and a flow control.

The RSHG is installed on top of the chimney and provides a controlled vacuum regardless of location, size or height of the chimney. The chimney fan can be used for both new and existing installations.

The RSHG is made of corrosion-resistant cast aluminium and is designed to operate in hot and corrosive environments.

The chimney fan withstands flue gas temperatures up to 200 °C and is delivered with a centrifugal impeller that ensures high efficiency. The wheel is driven by an enclosed heat-resistant asynchronous motor with permanently lubricated ball bearings that are developed for high temperatures.

The motor is placed so that it is protected from flue gas and a special cooling plate ensures that the motor is continuously kept cool.

The cable is heat-resistant and strain relieved and protected by a reinforced hose casing.

RSHG technical data

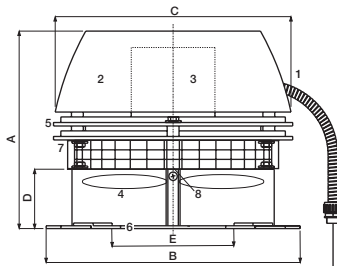

1. Motor cable
2. Top section
3. Motor
4. Vane

5. Cooling plate
6. Base plate
7. Hinges
8. Locking screws

Model	Motor data				Weight kg	Dimension [mm]				
	rpm	V	Amp	kW*		A	B	C ø	D	E ø
RSHG012-4-1	1400	1 x 230	0,3	0,03	14	275	365	350	85	165
RSHG014-4-1	1400	1 x 230	0,4	0,04	18	330	420	395	100	188

* Max effect at the motor shaft at ambient temperature: 20 °C

RPM is infinitely adjustable for all 1x230 V motors. • The motor is overload protected • Motor protection class IP 54, Insulation class F
Connection cord 120 cm, 6 core, 0.75 mm².

RSHG sound data

Sound levels to external surroundings

L_w (dB) measured in accordance with ISO 3744

Model	L _w (dL _w (dB))							L _p dB (A)
	125 Hz	250 Hz	500 Hz	1000 Hz	2000 Hz	4000 Hz	8000 Hz	
RSHG012-4-1	64	60	55	52	48	42	34	30
RSHG014-4-1	75	69	65	62	57	51	44	41

Sound levels to flue pipe

L_w (dB) measured in accordance with ISO 5136

Model	L _w (dL _w (dB))							L _w dB (A)	L _p dB (A)
	125 Hz	250 Hz	500 Hz	1000 Hz	2000 Hz	4000 Hz	8000 Hz		
RSHG012-4-1	72	65	59	49	47	41	31	61	53
RSHG014-4-1	82	73	63	58	52	48	38	68	61

Tolerance +/- 3 dB

L_w = sound effect level dB (reference: 1 pW)

L_p = sound pressure level dB (A) at 10 m distance from the fan at half spheric sound distribution

L_p (5 m) = L_p (10 m) + 6 dB

L_p (20 m) = L_p (10 m) - 6 dB

RSHG capacity diagram

The capacity diagrams shown below are only for illustration. Contact **exodraft** or your nearest dealer to calculate the correct fan size.

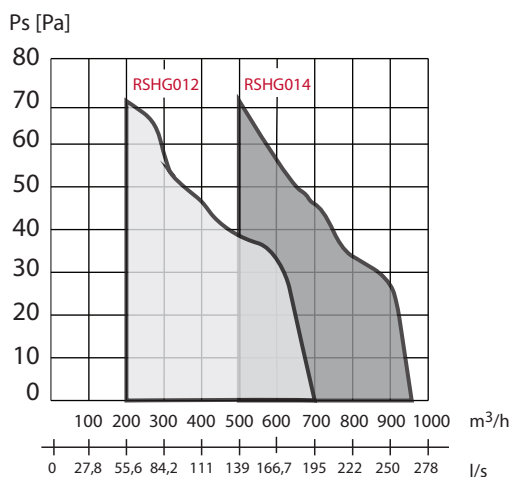

Type	Test flue diameters
RSHG012	Ø 200 mm
RSHG014	Ø 250 mm
at 1400 rpm	

PLEASE NOTE: The capacity diagram is measured at a flue gas temperature of 20 °C. The fan capacity changes with the temperature. Correction of system pressure loss for flue gas temperature higher than 20 °C is calculated:

$$P_{s_{20}} = P_{s_t} \times \frac{273 + t}{293}$$

P_s = static pressure

t = temperature measured in °C

Example:

System demand: 500 m³/h and 90 Pa at 180 °C

Fan selection: 500 m³/h and 139 Pa at 20 °C

RSVG chimney fan



Description

The RSVG is developed specifically for gas fireplaces and individual gas-fired boilers.

exodraft chimney fans provide a controllable negative pressure along the full length of the flue and chimney. The fans guarantee an optimum chimney draught irrespective of the placement, dimensions or height of the chimney.

The fan must be connected to an **exodraft** EFC21 control.

Design and construction

The chimney fan has a vertical discharge and an integrated monitoring system, consisting of a pressure control switch and a flow control. The RSVG is installed on top of the chimney and provides a controlled vacuum regardless of location, size or height of the chimney.

The RSVG chimney fan is made of corrosion-resistant cast aluminium and designed for operation in hot and corrosive environments. The chimney fan withstands flue gas temperatures up to 200 °C and is delivered with a centrifugal impeller, which enables high efficiency.

The chimney fan has an enclosed heat-resistant asynchronous motor with permanently lubricated ball bearings that is developed especially for use in high temperatures.

The motor is placed so that it is protected from flue gases and a special cooling vane wheel as well as cooling air slots that safely ensure continuous cooling of the motor. The cable is heat-resistant and strain relieved and protected by a reinforced hose casing.

RSVG technical data

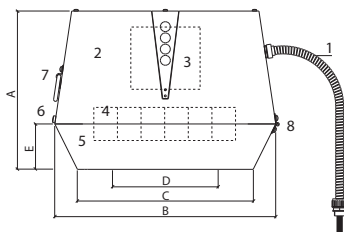

- | | |
|------------------------------|-------------------|
| 1. Connecting cable | 5. Bottom section |
| 2. Top section | 6. Locking screws |
| 3. Motor | 7. Handle |
| 4. Vane/centrifugal impeller | 8. Hinges |

Model	Motor data				Weight kg	Dimension [mm]				
	rpm	V	Amp	kW*		A	B x B	C x C	D ø	E
RSVG200-4-1	1400	1 x 230	0,4	0,07	18	280	390	310	200	80
RSVG250-4-1	1400	1 x 230	0,8	0,16	27	335	485	385	250	100
RSVG315-4-1	1400	1 x 230	1,8	0,37	37	380	580	465	315	115

* Max effect at the motor shaft at ambient temperature: 20 °C

RPM is infinitely adjustable for all 1x230 V motors.

Motor protection class IP54

Insulation class F

RSVG sound data

Sound levels to external surroundings

L_w (dB) measured in accordance with ISO 3744

Model	L _w (dL _w (dB))							L _p dB (A)
	125 Hz	250 Hz	500 Hz	1000 Hz	2000 Hz	4000 Hz	8000 Hz	
RSVG200-4-1	58	60	62	61	56	44	37	36
RSVG250-4-1	64	68	66	65	61	49	45	41
RSVG315-4-1	71	75	70	73	68	57	52	48

Sound levels to flue pipe

L_w (dB) measured in accordance with ISO 5136

Model	L _w (dL _w (dB))							L _w dB (A)	L _p dB (A)
	125 Hz	250 Hz	500 Hz	1000 Hz	2000 Hz	4000 Hz	8000 Hz		
RSVG200-4-1	65	62	62	58	48	41	30	63	55
RSVG250-4-1	72	69	65	63	56	48	41	68	61
RSVG315-4-1	74	73	70	71	63	53	47	74	69

Tolerance +/- 3 dB

L_w = sound effect level dB (reference: 1 pW)

L_p = sound pressure level dB (A) at 10 m distance from the fan at half spheric sound distribution

L_p (5 m) = L_p (10 m) + 6 dB

L_p (20 m) = L_p (10 m) - 6 dB

RSVG capacity diagram

The capacity diagrams shown below are only for illustration. Contact **exodraft** or your nearest dealer to calculate the correct fan size.

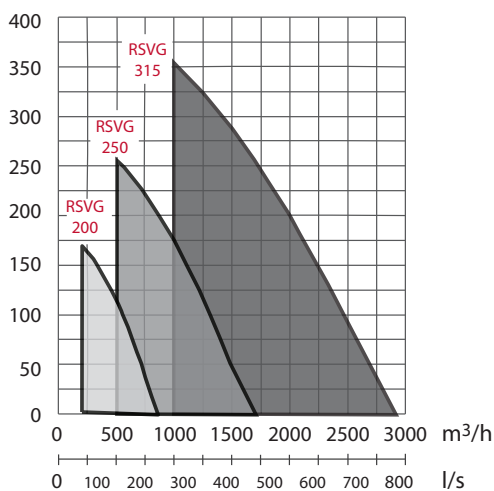

Type	Flue
RSVG200	ø 200 mm
RSVG250	ø 250 mm
RSVG315	ø 315 mm
at 1400 RPM	

PLEASE NOTE: The capacity diagram is measured at a flue gas temperature of 20 °C. The fan capacity changes with the temperature. Correction of system pressure loss for flue gas temperature higher than 20 °C is calculated:

$$P_{s_{20}} = P_{s_t} \times \frac{273 + t}{293}$$

P_s = static pressure

t = temperature measured in °C

Example:

System demand: 500 m³/h and 90 Pa at 180 °C

Fan selection: 500 m³/h and 139 Pa at 20 °C

RHG chimney fan



Description

The RHG160 is a chimney fan for use in combination with smaller gas fireplaces.

The RHG160 has a horizontal discharge and an integrated monitoring system, which consists of a pressure control switch and a flow meter. It is installed on top of

the chimney and provides a controlled vacuum in the flue pipe and chimney.

The chimney fan RHG160 ensures an optimum chimney draught regardless of location, size or height of the chimney.

Design and construction

The RHG160 is made of corrosion-resistant cast aluminium and is designed for operation in hot and corrosive environments.

It withstands flue gas temperatures up to 200 °C. The chimney fan has a centrifugal impeller that is enclosed with a heat-resistant asynchronous motor with permanently lubricated ball bearings that is developed especially for use in high temperatures.

RHG technical data

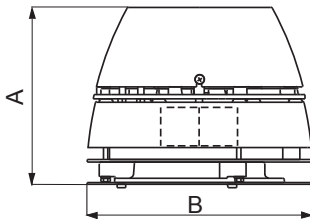

Model	Motor data				Weight kg	Dimension [mm]	
	rpm	V	Amp	kW*		A	B ø
RHG160-4-1	1400	1 x 230	0,4	0,09	10	238	290

* Max effect at the motor shaft at ambient temperature: 20 °C
 RPM is infinitely adjustable for all 1x230V motors.
 The motor is overload protected
 Motor protection class IP54
 Insulation class F

RHG capacity diagram

The capacity diagrams shown below are only for illustration. Contact **exodraft** or your nearest dealer to calculate the correct fan size.

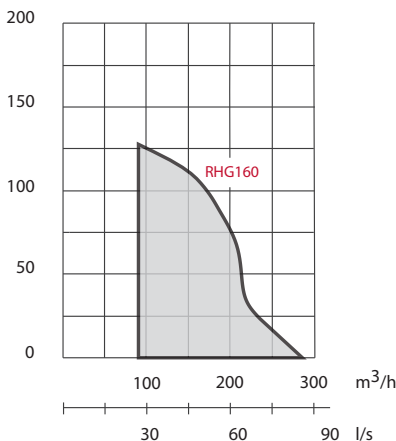

PLEASE NOTE: The capacity diagram is measured at a flue gas temperature of 20 °C. The fan capacity changes with the temperature. Correction of system pressure loss for flue gas temperature higher than 20 °C is calculated:

$$P_{S_{20}} = P_{S_t} \times \frac{273 + t}{293}$$

P_s = static pressure
 t = temperature measured in °C

Example:

System demand: 200 m³/h and 25 Pa at 180 °C
 Fan selection: 200 m³/h and 39 Pa at 20 °C

Type	Flue
RHG160	ø 160 mm
at 1400 RPM	

RSG chimney fan



Description

An **exodraft** chimney fan RSG provides a controllable negative pressure along the full length of the flue and chimney.

A fail-safe system is fitted in the fan which automatically measures the velocity of the flue gases. It can only be used when the velocity exceeds the pre-set and safe level. The fail-safe system prevents spillage from the gas appliance as well as any leaks of CO and poisonous gases.

Fan type RSG is installed on the external wall and thereby enables a gas appliance to be installed in a room with no chimney. The power of the fan will allow for long horizontal flues up to 15 meters.

A silencer type SLR is available as an accessory for the fan type RSG.

Design and construction

The fan is made to work in a hot environment and can withstand temperatures up to 180 °C at the flue exit.

The fans are made from galvanised sheet metal, fitted with a centrifugal impeller that is resistant to dirt in the flue gases.

The fans are fitted with an entirely closed, asynchronous motor with ball bearings sealed for life. The motor is constructed to provide reliable operation at a high temperature. It is made according to international classifications IP54 (protection class) and F (insulation). The motor is located inside the motor housing and thus separated from the flue gases.

The electrical connection is provided by a heat-resistant silicone cable withstanding 200 °C.

The built-in pressure switch in the chimney fan is wired to the **exodraft** control unit which supervises the fail-safe function. In case of insufficient chimney draught, the heating appliance will be shut down.

RSG technical data

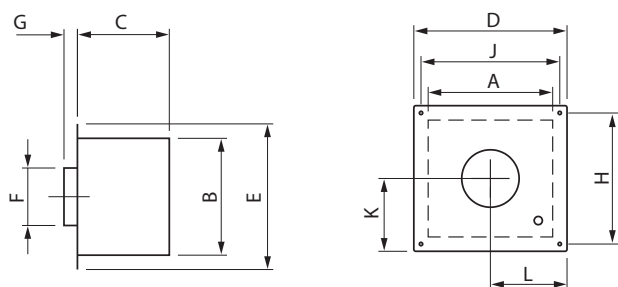

Model	Motor data				Weight kg	Dimension [mm]										
	rpm	V	Amp	kW*		A	B	C	D	E	F outside	G	H	J	K	L
RSG125-4-1	1400	1 x 230	0,3	0,04	11	265	250	220	336	320	∅121	35	280	296	153	157
RSG150-4-1	1400	1 x 230	0,2	0,05	14	325	310	240	400	380	∅146	35	340	360	181	186
RSG200-4-1	1400	1 x 230	0,4	0,11	20	405	380	275	478	453	∅196	35	413	438	215	221
RSG250-4-1	1400	1 x 230	0,8	0,14	31	522	482	338	600	560	∅247	60	516	556	271	279

* Max effect at the motor shaft at ambient temperature: 20 °C

RPM is infinitely adjustable for all 1x230 V motors.

The motor is overload protected.

Motor protection class IP54

Insulation class F

Silencer SLR (install accessory)				
Type	M	N Ø inside	O Ø inside	P Ø
SLR125-280	280	128	125	240
SLR150-280	280	153	150	265
SLR200-280	280	206	203	318
SLR200-600	600	206	203	318
SLR250-280	280	256	253	370
SLR250-600	600	256	253	370

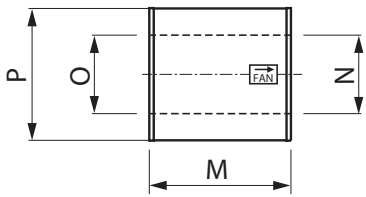

RSG sound data

Sound levels to flue pipe

L_w (dB) measured in accordance with ISO 5136

Model	L _w (dL _w (dB))							L _p dB (A)
	125 Hz	250 Hz	500 Hz	1000 Hz	2000 Hz	4000 Hz	8000 Hz	
RSG125-4-1	60	59	56	50	49	42	34	49
RSG150-4-1	61	66	61	56	53	47	40	55
RSG200-4-1	69	72	68	62	59	55	49	61
RSG250-4-1	78	71	62	57	52	50	51	63

Sound levels to external surroundings

L_w (dB) measured in accordance with ISO 3744

Model	L _w (dL _w (dB))							L _w dB (A)	L _p dB (A)
	125 Hz	250 Hz	500 Hz	1000 Hz	2000 Hz	4000 Hz	8000 Hz		
RSG125-4-1	66	59	48	44	40	30	21	54	29
RSG150-4-1	75	67	52	50	44	36	29	61	35
RSG200-4-1	80	69	59	56	51	45	36	66	41
RSG250-4-1	71	72	67	61	61	62	60	70	42

Sound absorbed using silencer SLR (L_w to flue pipe)

Model	L _w (dL _w (dB))						
	125 Hz	250 Hz	500 Hz	1000 Hz	2000 Hz	4000 Hz	8000 Hz
SLR125-280	4	6	11	21	18	12	12
SLR150-280	2	4	11	19	14	14	9
SLR200-280	1	2	10	16	12	12	7
SLR250-280	1	1	6	14	5	5	4

Tolerance +/- 3 dB

L_w = sound effect level dB (reference: 1 pW)

L_p = sound pressure level dB (A) at 10 m distance from the fan at half spheric sound distribution

L_p (2 m) = L_p (1 m) - 6 dB

RSG capacity diagram

The capacity diagrams shown below are only for illustration. Contact **exodraft** or your nearest dealer to calculate the correct fan size.

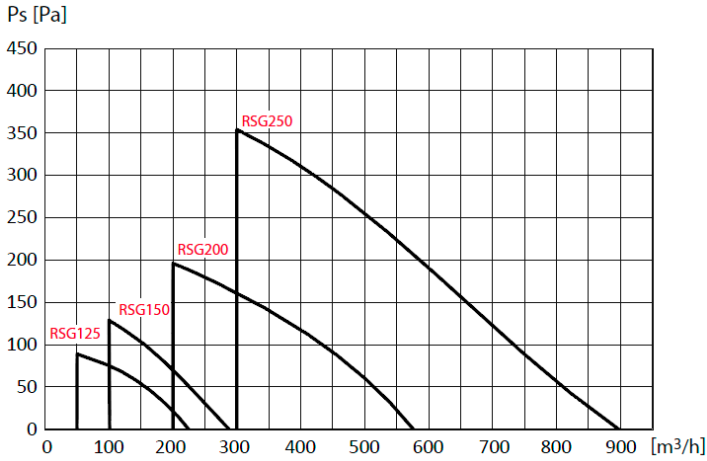

Type	Flue
RSG125	ø 125 mm
RSG150	ø 150 mm
RSG200	ø 200 mm
RSG250	ø 250 mm
at 1400 RPM	

PLEASE NOTE: The capacity diagram is measured at a flue gas temperature of 20 °C. The fan capacity changes with the temperature. Correction of system pressure loss for flue gas temperature higher than 20 °C is calculated:

$$P_{s_{20}} = P_{s_t} \times \frac{273 + t}{293}$$

P_s = static pressure

t = temperature measured in °C

Example:

System demand: 300 m³/h and 90 Pa at 180 °C

Fan selection: 300 m³/h and 139 Pa at 20 °C

Inline fan CFIR

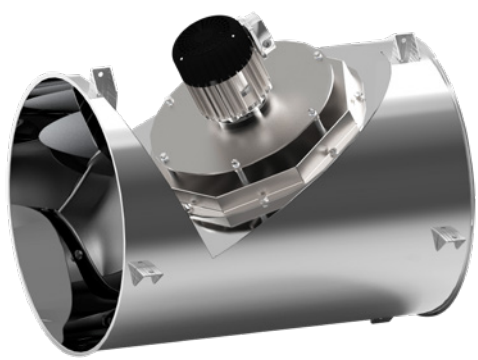

Description

CFIR is a heat-resistant inline fan which supplies gas, oil and steam installations with mechanical draught. Designed to work at continuous flue gas temperatures up to 600 °C, the CFIR can be installed both vertically and horizontally in your duct system, indoors as well as outdoors (from -40 °C to +50 °C), providing you with more freedom of design.

Its stable construction makes it suitable for pulsating boilers. All stainless steel in accordance with EN1.4404(316L) for installation in corrosive environments. The cylindrical design provides a seamless and aesthetically pleasing integration with cylindrical ducts and chimney flues. It is designed to meet EN1.6475 demands for gas seal. Protected by a reinforced hose casing.

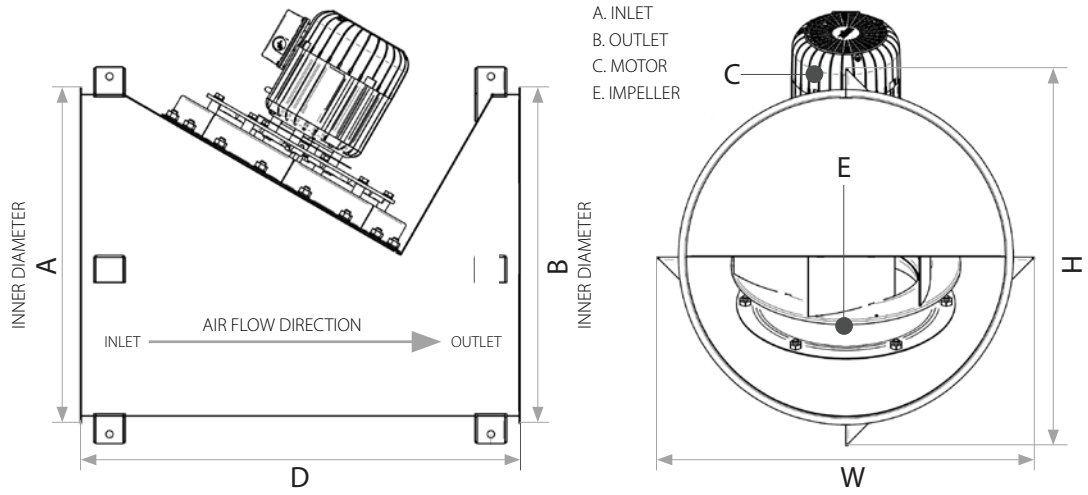

Type	Motor data					Frequency inverter		Dimensions						Temp. rating	
	RPM (nominal)	RPM (max.)	Voltage [V]	Power [kW]	Current [A]	Voltage [V]	Current [A]	Weight [kg]	A Ø [mm]	B Ø [mm]	D [mm]	H [mm]	W [mm]		Chimney Ø [mm]
CFIR200	1750	2400	3 x 208 -240*	0.75	3.0	3 x 208 -240	4.3	23	406	406	600	568	491	300 **	Maximum 600 °C
CFIR300	1750	2200	3 x 380 -400*	1.5	3.7	3 x 380 -400	5.6	38	508	508	700	662	599	350 **	
CFIR400	1750	1950	3 x 380 -400*	2.2	4.8	3 x 380 -400	7.5	56	610	610	850	784	700	400 **	
CFIR500	1750	1950	3 x 380 -400*	3.0	7.3	3 x 380 -400	11.5	75	711	711	1000	859	802	500 **	

* exodraft frequency inverter required
 ** Nominal chimney connection

Complete solution

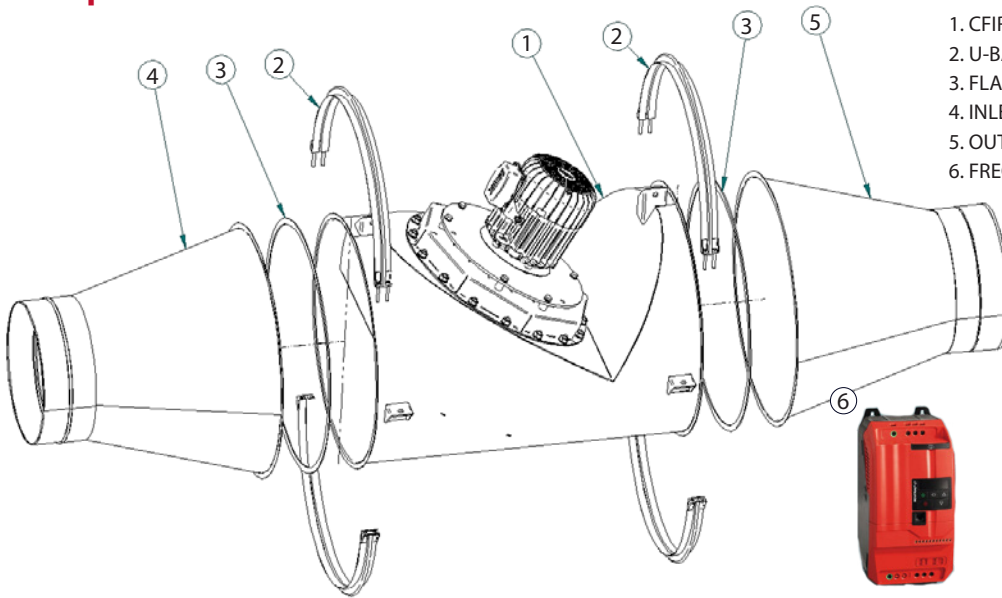

- 1. CFIR INLINE FAN
- 2. U-BAND (2x)
- 3. FLANGE GASKET (2x)
- 4. INLET CONE (NIPPLE COUPLING)
- 5. OUTLET CONE (SLEEVE COUPLING)
- 6. FREQUENCY INVERTER (REQUIRED)



On the next page, you find an overview of the various components in different sizes, allowing you to select a matching set for the sizing you need.

CFIR capacity diagram

The capacity diagrams shown below are only for illustration. Contact **exodraft** or your nearest dealer to calculate the correct fan size.

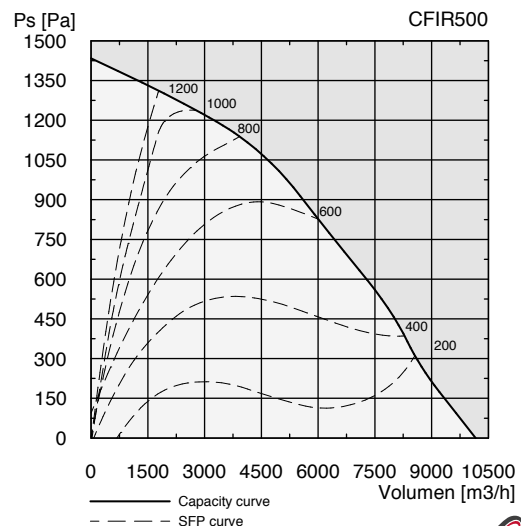
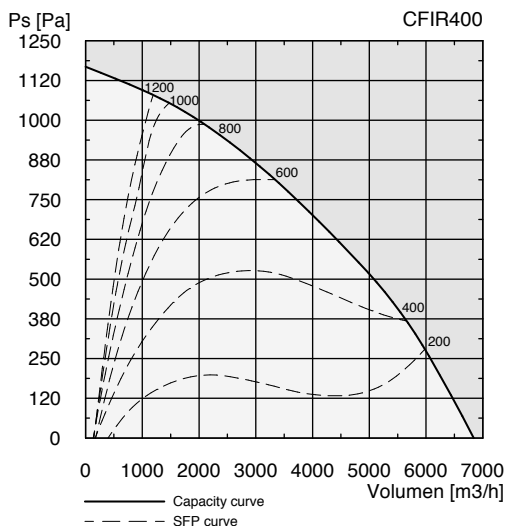
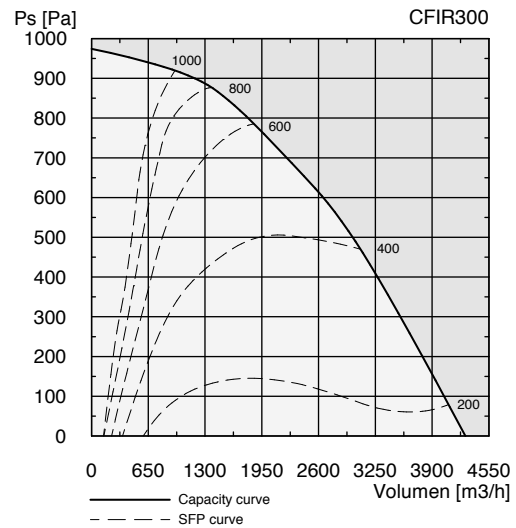
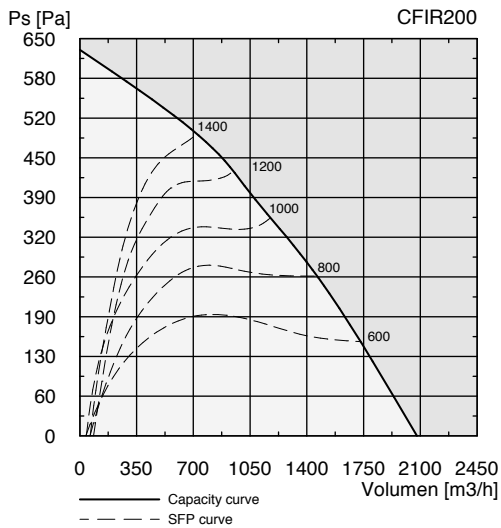

CFIR configurations

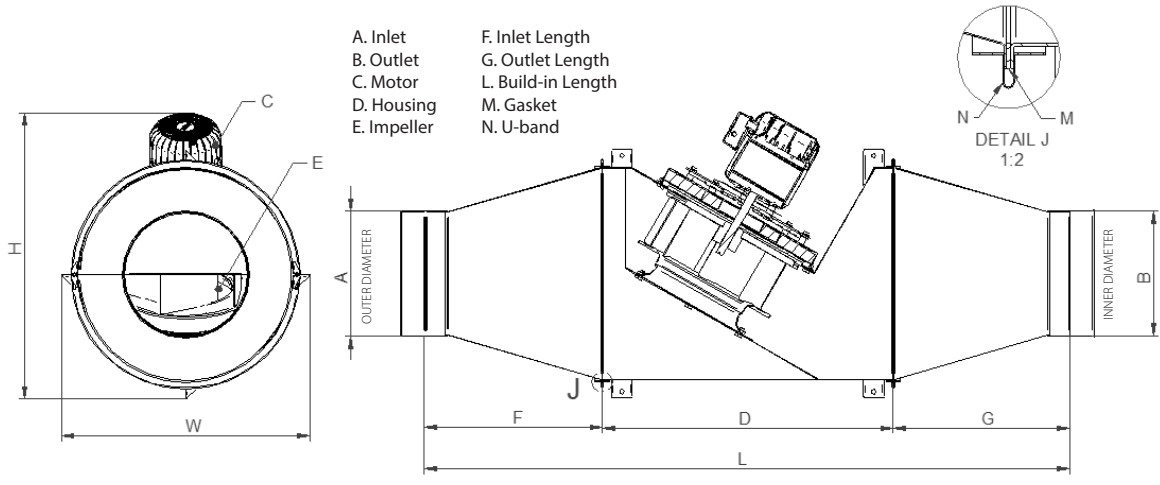

Model	Fan			Cone Inlet	Cone Outlet	U-band	Gasket	Dimensions & Weight									
	RPM (max)	Voltage [V]	Power [kW]					Weight [kg]	A [mm]	B [mm]	D [mm]	F [mm]	G [mm]	H [mm]	L [mm]	W [mm]	Chimney [mm]
CFIR200	2400	3 x 208 -230*	0.75	CFIR200-STUDS250	CFIR200-MUFFE250	CFIR200-UBAND	CFIR200-PAK	30	250.5	251.3	600	338	333	568	1272	491	250**
				CFIR200-STUDS300	CFIR200-MUFFE300			29	300.5	301.3		251	246		1097		
CFIR300	2200	3 x 380 -480*	1.5	CFIR300-STUDS300	CFIR300-MUFFE300	CFIR300-UBAND	CFIR300-PAK	50	300.5	301.3	700	431	426	662	1557	599	300**
				CFIR300-STUDS350	CFIR300-MUFFE350			48	350.5	351.3		343	339		1382		
				CFIR300-STUDS400	CFIR300-MUFFE400			47	400.5	401.3		257	251		1208		
CFIR400	2000	3 x 380 -480*	2.2	CFIR400-STUDS400	CFIR400-MUFFE400	CFIR400-UBAND	CFIR400-PAK	71	400.5	401.3	850	435	429	784	1614	700	400**
				CFIR400-STUDS500	CFIR400-MUFFE500			67	500.5	501.3		260	255		1265		
CFIR500	2000	3 x 380 -480*	3.0	CFIR500-STUDS500	CFIR500-MUFFE500	CFIR500-UBAND	CFIR500	93	500.5	501.3	1000	436	431	859	1867	802	500**
				CFIR500-STUDS600	CFIR500-MUFFE600			89	600.5	601.3		262	257		1519		

* exodraft frequency inverter required
 ** Nominal chimney connection

Example of asymmetrical configuration

Small inlet cone with large outlet cone

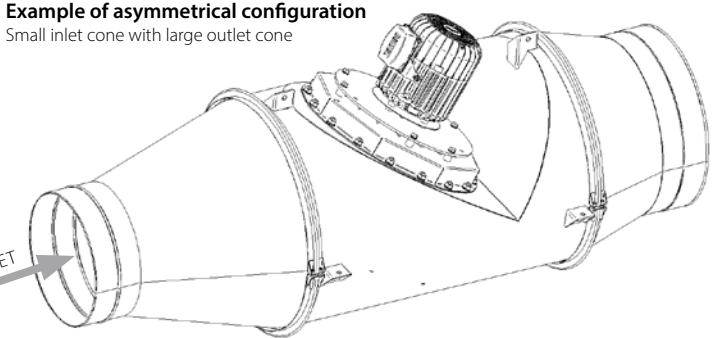
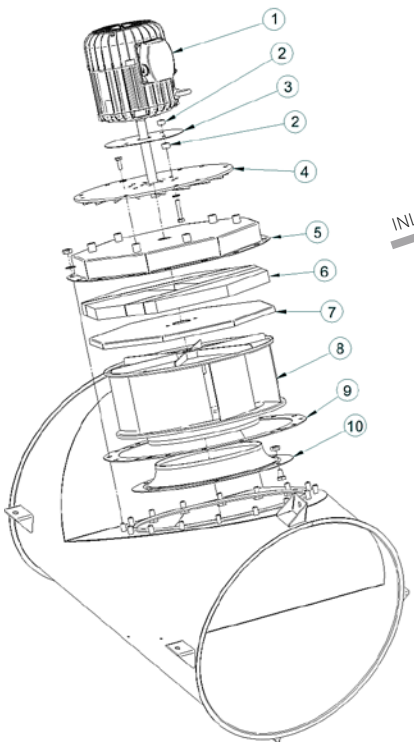

1. MOTOR
2. SPACER
3. MOTOR HEAT SHIELD
4. MOTOR PLATE DOMEL
5. MOTOR MOUNTING PLATE
6. INSULATION
7. INSULATION COVER
8. IMPELLER
9. GASKET
10. INLET CONE FOR IMPELLER

Fan model	Cone (inlet)	Cone (outlet)	U-band	Gasket
1 pcs.	1 pcs.	1 pcs.	2 pcs.	2 pcs.
CFIR300	CFIR300-STUDS300	CFIR300-MUFFE400	CFIR300-UBAND	CFIR300-PAK

Greasefan GSV

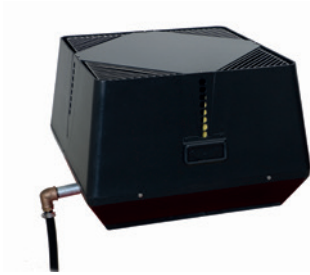

Design and construction

GSV chimney fans are built for temperatures up to 250 °C in continuous rating and made from cast aluminium. All screws and bolts are stainless steel.

The motor is a temperature-resistant, encapsulated induction motor with sealed and maintenance-free ball bearings, sitting outside the air volume flow.

The cable is heat-resistant, strain-relieved and shielded externally with a reinforced hose. These measures give the chimney fan high operational reliability and long service life.

The grease fan chimney fan is hinged, allowing chimney cleaners to easily clean the chimney and enabling easy regular cleaning.

The drain opening is fitted with a stainless steel grid as protection.

Description

The **exodraft** Grease Fan chimney fan with integrated grease drain is a specially built chimney fan with a vertical discharge for grills and kitchen exhaust. When installed on top of a chimney the chimney fan generates a vacuum in the flue pipe and in the chimney.

The grease fan is suitable for grills and kitchen exhausts. With its integrated grease drain, grease drip pan and exchangeable granule cushion it is the ideal solution for greasy exhaust air.

GSV technical data

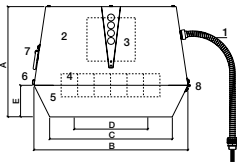

- 1. Connecting cable
- 2. Upper part
- 3. Motor
- 4. Impeller
- 5. Lower part
- 6. Locking screws
- 7. Handle
- 8. Hinge

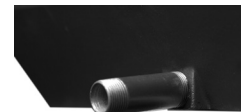

Integrated fat drain on the Grease Fan

Model	Motor Data				Weight kg	Dimensions (mm)				
	rpm	V	Amp	kW*		A	B x B	C x C	D Ø	E
GSV315-4-1	1400	1 x 230	1,8	0,37	45	430	650	525	280	130
GSV400-4-1	1400	1 x 230	2,6	0,60	47	430	650	525	280	130
GSV400-4-2**	1720	3 x 230	4,0	0,75	52	460	650	525	400	130

* Power consumption for ambient temperature of 20°C
 ** Frequency converter required
 Density class IP54, Insulation class F.

GSV capacity diagram

The capacity diagrams shown below are only for illustration. Contact **exodraft** or your nearest dealer to calculate the correct fan size.

GSV315 and GSV400

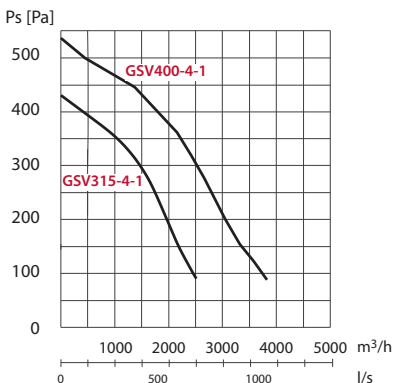

GSV400-4-2

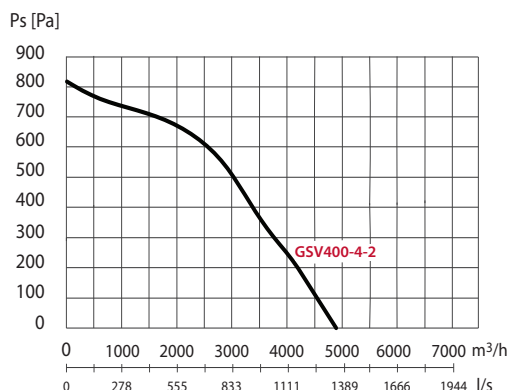

EFC16 and EFC35/EFC35S manual controls



EFC16



EFC35/EFC35S

Description

EFC16 and EFC35/EFC35S are electronic speed controls used to manually control **exodraft** chimney fans.

The EFC16 or EFC35/EFC35S speed controls adjust the speed of the chimney fans and thereby makes it possible to control the fan's capacity (draught) in the range 25–100 %.

They have a built-in ON/OFF switch in the control knob, a built-in minimum-speed trimmer, and a LED to indicate operation. The controls are CE-certified.

Function

The EFC16 and EFC35/EFC35S speed controls are for manual control. When the knob on these controllers is turned to the right, it will click, and the fan will turn on at full rpm. As the knob is rotated clockwise, the fan speed will be reduced. To turn the fan off, the knob must be turned all the way anti-clockwise, until it has passed the on/off point again.

EFC16 or EFC35/EFC35S control units must have a REP-AFB isolation switch installed on the chimney. The isolation switch must be installed by an authorised electrician.

EFC16 and EFC35/EFC35S technical data

Description	EFC16	EFC35	EFC35S
Height (mm)	85	102	120
Width (mm)	85	74	80
Depth (mm)	52	67	77
Load (Amp)	Max. 1,5 A	Max. 3,5A	Max. 3,5A
Fuse (Amp)	T 1.6 A	T 4 A	T 4 A
Power supply	230 V AC, 50 Hz	230 V AC, 50 Hz	230 V AC, 50 Hz
Ambient temperature	0 °C to +40 °C	0 °C to +35 °C	0 °C to +35 °C
IP-rating	IP30	IP20	IP44
Casing material	ABS	ABS	ABS
Colour	White	White	White
Usable with the following fans listed in this brochure:	RS009/012/014/016 RSV009/012/014 RSV160/200/250	RSV016 RSV315 RSV400	All 230V models

EFC16

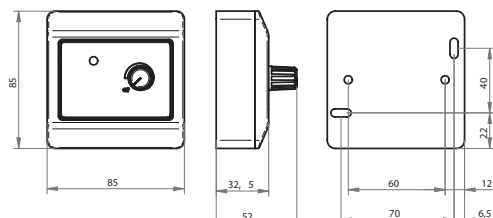

EFC35/EFC35S

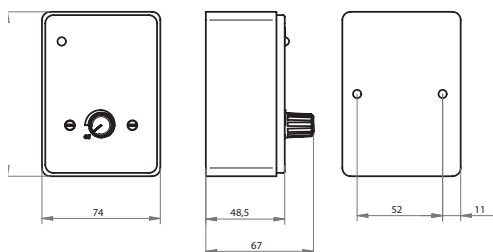

EFC18



EFC18

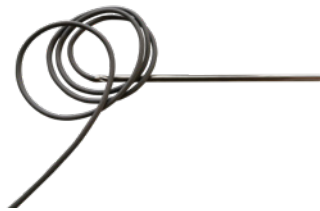

Temperature sensor

Description

The EFC18 is a manual nine-step speed control with an integrated automatic START/STOP. It features a boost function, to make lighting the fire easier. The EFC18 controller comes with a temperature sensor to be fitted under the fan.

Function

The EFC18 controller switches the chimney fan on with a simple press on the button on the control panel. To ensure sufficient up-draught when lighting the fire, the fan will run at full speed for seven minutes unless turned down manually. After the start up period the fan will modulate down to the speed it was running at last time it was in operation.

When re-stoking the fire, press the operating button once. The EFC18 control will then run the fan in boost mode for three minutes to avoid smoke and dust in the room.

The EFC18 temperature sensor, which is installed under the chimney fan, registers falling temperature. As the fire burns out and the flue temperature drops, the controller will (at a pre-set temperature of 20, 40 or 80 °C) run the fan for 45 minutes before stopping. This ensures that all the wood in the fire has combusted and the fan will automatically start if a chimney temperature above a set level is registered.

The EFC18 can always be adjusted manually during operation, but the temperature sensor will prevent the fan from being turned off while the fire is still burning and thereby avoid damaging the fan motor and eliminate the risk of spillage.

A REPSW2x16 isolation switch must be fitted to the chimney when the EFC18 control system is installed. The isolation switch must be installed by an authorised electrician.

EFC18 technical data

Description	EFC18
Height (mm)	85
Width (mm)	85
Depth (mm)	32,5
Load (Amp)	1,2 A
Fuse (Amp)	T 1,25 A
Power supply	230 V AC, 50 Hz
Temperature sensor range	-50 °C to +400 °C
Ambient temperature	0 °C to +40 °C
IP-rating	IP30
Casing material	ABS
Colour	White
Usable with the following fans listed in this brochure:	RS009/012/014/016 RSV009/012/014 RSV160/200/250

EFC18

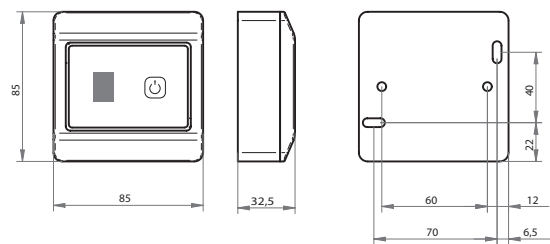

Xzense wireless smart control



Xzense control panel

Optional accessories (to be ordered separately)

- Mounting kit for power unit on steel chimney
- Repeater unit for maintaining signal strength for those installations where the control panel and power unit are placed far apart
- XTP pressure sensor
- Additional Xzense control panel
- Additional USB charger cable

Xzense technical data

Description	Xzense
Frequency for radiocommunications	868 MHz Bluetooth LE 2.4 Ghz
Range	~ 18 m inside buildings
Power unit	
Dimensions (w x h x d)	122 x 120 x 55 mm
Material	PC
Ingress protection	IP54
Voltage	230 V \pm 10 % / 50 Hz
Fuse	T 2,0 A
Power output	2 A
Operating temperature	-30 °C to +60 °C
Power consumption (standby)	1 W
Control panel	
Dimensions (w x h x d)	77 x 86 x 25 mm
Voltage	5 V (USB)
Material	ABS
Operating temperature	0 °C to +40 °C
Ingress protection	IP20
Battery type	Li-Po
Battery life (full charge)	approx. 30 days (normal use)
Temperature sensor	
Dimensions	\varnothing 6 x 200 mm
Type	PT 1000
Material	Stainless steel
Ambient temperature	Sensor: -50 °C to +50 °C Cable: -50 °C to +125 °C

Description

The Xzense wireless remote from **exodraft** is used for chimney fans for solid fuel fires, such as wood-burning stoves or open fireplaces. Xzense can be paired with your iOS or Android smart phone via Bluetooth.

Xzense consists of:

- Xzense wireless control panel with touchscreen
- Power unit with 5 metre cable that plugs into the mains
- Temperature sensor to be placed under the fan (must be connected to the power unit)
- Wall-mounting kit for control panel

The Xzense control panel helps you start and stop the fan and regulate its speed. The panel stores the last operating settings and allows you to access current and historical performance data from the display.

When lighting the fire, activate Xzense's boost function and the chimney fan will boost the chimney draught for ten minutes (default setting) to help establish the fire and prevent smoke backflow. Once the boost period expires, Xzense will automatically return to the last used setting to balance the fire.

Once the fire is smouldering, Xzense will notify you that it is time to refuel. If you choose to refuel, Xzense will prompt the chimney fan to return to its maximum speed for three minutes (default setting) to prevent smoke from spilling into the room while the oven door is open.

If you choose not to refuel, the Xzense will instead go into after run mode for 30 minutes (default setting) to ensure that there are no more embers left in the fireplace. The fan will automatically turn off and the heat from the dwelling is not sucked away.

The default run times for boost and after run modes can be changed in the settings menu.

Xzense also has a ventilation mode for ventilating the fireplace at your convenience. This can be useful while cleaning the fireplace to prevent ash and dirt from escaping into the room.

The optional eXotelligence mode, which can be activated from the settings menu, is a self-learning function that stores data from previous lightings and helps you create the best possible chimney draught by automatically adjusting the speed of the chimney fan based on weather conditions and temperature. This mode also helps to further reduce particle emission.

See more at www.xzense.com

EFC21 control

Description

exodraft controller EFC21 is developed for gas fireplaces where an **exodraft** chimney fan is installed.

The control system supervises the fail-safe function. In case of insufficient chimney draught, the EFC21 will shut off the gas supply.

Function

By activating EFC21, the chimney fan will immediately start up at full speed. When the fail-safe supervision confirms sufficient chimney draught, the fireplace can be lit and the fan speed will adjust to the pre-set value which was set during commissioning.

The controller has a step-up function and a 15-second built-in delay function to avoid nuisance cut-outs. When EFC21 is turned off, the chimney fan stops. It is possible to pre-set a post-purge period of 3 minutes.

The step-up function is part of the fail-safe system. Should the draught fail during normal operating conditions, the controller will increase the fan speed to compensate. This usually occurs on windier days than the commissioning day. If sufficient draught cannot be re-established, the EFC21 will shut off the gas supply.

Accessories



SMG12: Solenoid valve for EFC21 for 1/2" pipe



SMG14: Solenoid valve for EFC21 for 1/4" pipe.

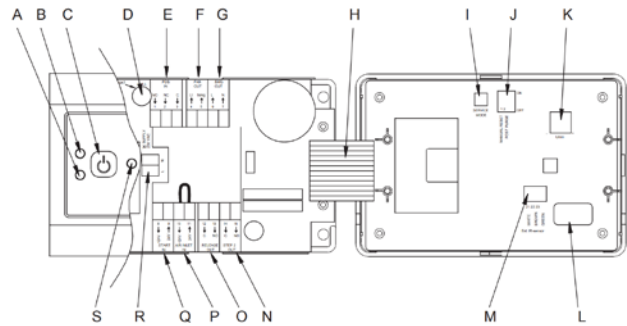
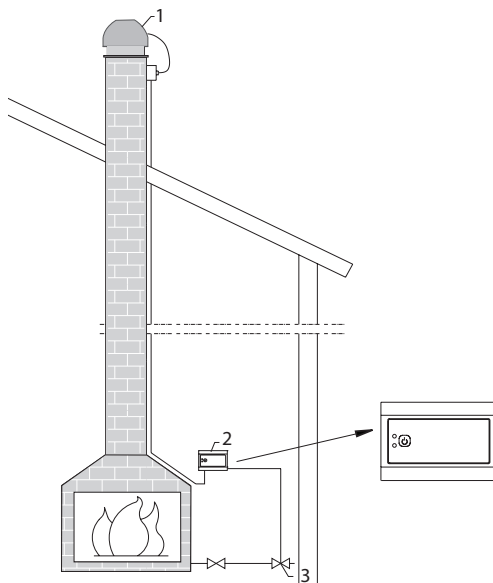

Description	Data EFC21
Height (mm)	85
Width (mm)	126
Depth (mm)	32
Fuse rating (amps) (A)	3,15 AT
Fail safe (B) Pressure differential switch (PDS)	24 V DC (Closed circuit supply)
Output to chimney fan (C)	1,8 A/230 V (AC 3)
Output to solenoid valve (SMG) (D)	230 V AC max. 100 V A
Dipswitch options (E)	<ul style="list-style-type: none"> • Manual reset • Post-purge 3 min. period
Set-point running speed (F)	Potentiometer on PCB
Supply (G)	230 V +/- 10 %, 50 Hz
Input for external on/off switch (H)	24 V DC (Closed circuit supply)
Release out Relay (I)	Max. 3 A 230 V AC / 3A 30 V DC (Fused: 3,15AT)
Operating temperature	-10 °C to +40 °C
Degree of protection	IP30
Material	ABS
Colour	White
CE-Approval No.	0063BN1144 based on EN298 (2003)
Usable with the following chimney fans in this brochure	RHG, RSHG, RSVG, RSG

The system consists of:

1. Chimney fan
2. Controller EFC21
3. Solenoid valve SMG (order separately)

EBC10v2 automatic control



EBC10v2



XTP sensor

Description

The EBC10v2 is an automatic control with a pressure transducer (XTP) for one boiler or other installations with one heat source.

With the help of the XTP sensor, which is installed in the chimney, the constant pressure is monitored and maintained by regulating the speed of the chimney fan.

EBC10v2 offers the possibility of an external entry point for a pressure switch or alarm sensor as well as the possibility of an alarm exit point for, for instance, a building management system.

Function

When the boiler or the heating system starts, a signal is sent to the EBC10v2 which starts the chimney fan. When the control receives the signal that the desired chimney vacuum has been reached, a signal is sent to start the burner of the boiler.

The required chimney draught is therefore always guaranteed when you start the boiler, thereby the best and most economical operating conditions are ensured.

If the draught in the chimney falls below the desired level, the speed of the chimney fan is regulated until the desired chimney draught is re-established.

EBC10v2 technical data

Description	EBC10v2
EBC10v2EU01	
Dimension (W x H x D)	175 x 175 x 110 mm
Weight	1,5 kg
IP-rating / material	IP54 / ABS PA758
Voltage	230 V AC $\pm 10\%$, 50 Hz $\pm 1\%$
Power consumption	475 W (3,7 A)
Fuse	4.0T
Temperature	-20 °C to +50 °C
Monitoring range	-500 to +500 Pa
XTP-sensor	
Dimension (W x H x D)	82 x 80 x 55 mm
Operating temperature	-25 to +50 °C
Monitoring range	0 to +150 Pa
Max. distance between EBC24 and XTP sensor	100 m
IP-rating	IP65
EBC10v2 Inputs	
Digital boiler inputs (1)	10-230 V AC/DC
Pressure sensor (XTP) input	0 to 10 V DC, 20 mA
Pressure switch (PDS) input	24 V DC, 20 mA
EBC10v2 Outputs	
Digital boiler outputs (1)	250 V AC, 8 A,
Motor regulator	Supply voltage -3 %, 3 A
24 V DC power supply	100 mA
Alarm output relay	250 V AC, 8 A

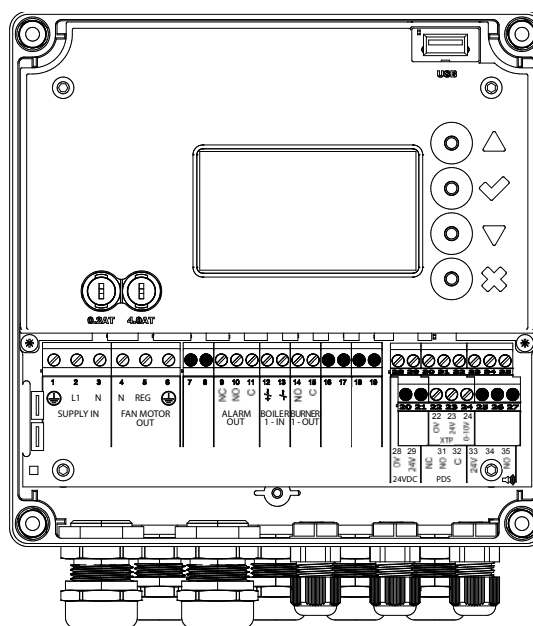

● = not available on EBC10v2 (see EBC24)

EBC24 automatic control



EBC24

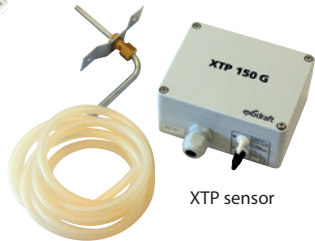

XTP sensor

Description

The EBC24 is an automatic control system for boiler installations and for installations in which multiple heat sources are connected to the same chimney. The control monitors and maintains a specific draught by maintaining a constant pressure.

The EBC24 system consists of an EBC24 control, which can be positioned anywhere, and a pressure transducer (XTP sensor) which is positioned in the chimney.

Function

In installations where more fireplaces are connected to the same chimney, the chimney fan operates continuously. The EBC24 controller monitors and maintains a specific draught by maintaining a constant pressure. The pressure in the chimney is measured by the XTP sensor. If the draught falls below the set value, the speed of the chimney fan is regulated until the draught reaches the required level again.

The EBC24 has two heating appliance interlock circuits as standard and can be expanded in multiples of four with the use of additional relay boards (ES12).

A self-diagnostic panel with LEDs monitors all connection terminals for easy service and troubleshooting. The EBC24 also has an alarm output for a BMS-system. An alarm via a buzzer can be made through the buzzer output.

The EBC24 has terminals for connecting a RS485 communication BUS.

EBC24 technical data

Description	EBC24
EBC24EU01/EBC24EU02	
Dimension (W x H x D)	175 x 175 x 110 mm
Weight	1,5 kg
IP-rating / material	IP54 / ABS PA758
Voltage	230 V AC $\pm 10\%$, 50 Hz $\pm 1\%$
Power consumption	475 W (3,7 A)
Fuse	4.0T
Temperature	-20 °C to +50 °C
Monitoring range	-500 to +500 Pa
XTP-sensor	
Dimension (W x H x D)	115 x 90 x 55 mm
Operating temperature	-25 to +50 °C
Monitoring range	0 to +150 Pa
Max. distance between EBC24 and XTP sensor	100 m
IP-rating	IP65
EBC24EU01/ EBC24EU02 Inputs	
Digital boiler inputs (2)	18-230 V AC/DC
Pressure sensor (XTP) input	0 to 10 V DC, 20 mA
Pressure switch (PDS) input	24 V DC, 20 mA
EBC24EU01/ EBC24EU02 Outputs	
Digital boiler outputs (2)	250 V AC, 8 A,
Motor regulator	Supply voltage -3 %, 3 A
Motor start/stop relay	250 V AC, 8 A
Control signal 0-10 VDC	20 mA
24 VDC power supply	100 mA
Alarm output relay	250 V AC, 8 A

- EBC24EU01** Control for indoor installation
- EBC24EU02** Control for outdoor installation

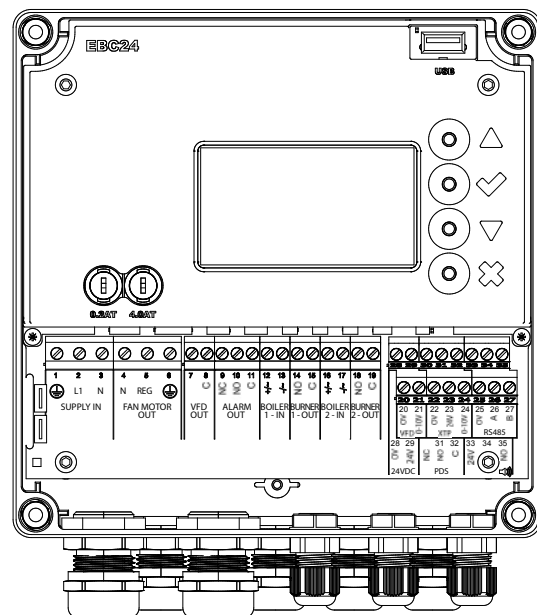

Frequency Inverter FRK



Description

The frequency inverters - or variable speed drives (VSD) – are used for regulating the speed of the chimney fans with three-phase motors. All CFIR inline fans have special EC (electronically controlled) motors that can only be regulated by using a frequency inverter. The inverters are used in combination with the controllers EBC22/24 or the manual controller Pot S. All FRK frequency inverters are pre-programmed with a unique software tested and designed to suit each fan.

Type	Description	Power supply
FRK-030	For inline fan CFIR200, Density class IP20	1 x 230 V
FRK-031	For inline fan CFIR200, Density class IP66	1 x 230 V
FRK-032	For inline fan CFIR300, Density class IP20	3 x 400 V
FRK-033	For inline fan CFIR300, Density class IP66	3 x 400 V
FRK-034	For inline fan CFIR400, Density class IP20	3 x 400 V
FRK-035	For inline fan CFIR400, Density class IP66	3 x 400 V
FRK-036	For inline fan CFIR500, Density class IP20	3 x 400 V
FRK-037	For inline fan CFIR500, Density class IP66	3 x 400 V
FRK-040	For chimney fan RSV400-4-2	1 x 230 V
FRK-041	For chimney fan RSV450-4-2	1 x 230 V
FRK-042	For chimney fan RSV400-4-2	3 x 400 V

Cover plate

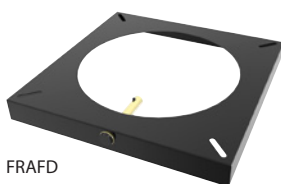

FRAFD

Description

Cover plate for brick and steel chimneys (to cover anti-vibration mat and flange).

Type	Description	Fits chimney fan type
FR1AFD6	Cover plate steel chimney	RSV009, RSV160
FR2AFD6	Cover plate steel chimney	RSV012, RSV200, RSVG200, RS009, RS255, RSHT009
FR3AFD6	Cover plate steel chimney	RSV014, RSV250, RSVG250, RS012, RS014, RS285, RSHG012, RSHG014, RSHT012, RSHT014
FR4AFD6	Cover plate steel chimney	RSV016, RSV315, RSVG315, RS016, RSV400, RSV450, RSHT016
FR1AFD6-001	Cover plate brick chimney	RSV009, RSV160
FR2AFD6-001	Cover plate brick chimney	RSV012, RSV200, RSVG200, RS009, RS255, RSHT009
FR3AFD6-001	Cover plate brick chimney	RSV014, RSV250, RSVG250, RS012, RS014, RS285, RSHG012, RSHG014, RSHT012, RSHT014
FR4AFD6-001	Cover plate brick chimney	RSV016, RSV315, RSVG315, RS016, RSV400, RSV450, RSHT016

FR flange

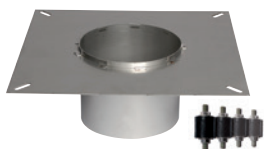

FR (and 4 vibration dampers)

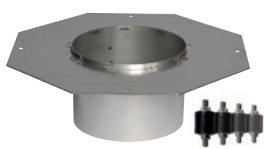

FR-02 (and 4 vibration dampers)

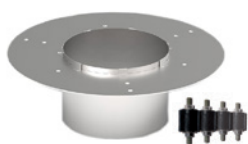

FR5 (and 4 vibration dampers)

Description

FR flanges from **exodraft** are used to install **exodraft** chimney fans on steel chimneys.

The flanges are made of stainless steel and ensure that the chimney fans have a flat and level installation base. The flange is supplied with four vibration dampers that reduce vibrations.

The diameter of the flange spigot is 3 or 5 mm smaller than the diameter of the chimney, depending on whether or not it is with drainage. For example, the diameter of the spigot of an FR1200 is \varnothing 197 mm, designed to fit into a chimney opening with a \varnothing 200 mm diameter. The diameter of the spigot of an FR1200D is \varnothing 195 mm, designed to fit into a chimney opening with a \varnothing 200 mm diameter.

The flange range caters for all types of chimney fans and chimneys. Flanges with diameters other than those shown in the table can be made to order.

Type	mm	Chimney diameter	Chimney fan
FR1	272 x 272	125 - 150 - 175 - 180 - 190 - 200	RSV009, RSV160
FR1-D	272 x 272	150 - 190 - 200	RSV009, RSV160
FR2	310 x 310	125 - 150 - 160 - 175 - 180 - 190 - 200 - 250	RS009, RS255, RSV012, RSV200, RSVG200, RSHT009
FR2-D	310 x 310	150 - 190 - 200	RS009, RS255, RSV012, RSV200, RSVG200, RSHT009
FR3	395 x 395	150 - 175 - 180 - 190 - 200 - 250 - 300 - 350	RS012, RS014, RS285, RSV014, RSV250, RSVG250, RSHG012, RSHG014, RSHT012, RSHT014
FR3-D	395 x 395	150 - 190 - 200	RS012, RS014, RS285, RSV014, RSV250, RSVG250, RSHG012, RSHG014, RSHT012, RSHT014
FR4	500 x 500	200 - 250 - 300 - 350 - 400 - 450	RS016, RSV016, RSV315, RSV400, RSV450, RSVG315, RSHT016
FR2-02	310 x 310	150 - 160 - 180 - 190 - 200	RS009-02
FR3-02	395 x 395	150 - 180 - 190 - 200	RS012-02
FR5	300 x 300	100 - 125 - 150	RHG160

Spigot length 120 mm

Other fitting accessories

Levelling screws



RSD

Four levelling screws type RSD can be installed between the fan and the chimney to create dilution air in brick chimneys if the temperature in the chimney is too high. If dilution air is required, it is important to take the increased capacity need into consideration when sizing the fan system.

Rainshield



RS Rainshield



RSV Rainshield

Rain protection against driving rain.

Type	Description	Fits chimney fan type
1105619	Rainshield	RS009, RSHT009
1105621	Rainshield	RS012, RSHG012, RSHT012
1105623	Rainshield	RS014, RSHG014, RSHT014
1100178	Rainshield	RSV009, RSV160
1100179	Rainshield	RSV012, RSV200, RSVG200
1100192	Rainshield	RSV014, RSV250, RSVG250

Isolation switch



REP-AFB



REPAFB3P



REPSW2x16

It is a legal requirement that an isolation switch is installed in the immediate vicinity of the chimney fan, so that, for example, chimney sweeps can disconnect the electrical current to the chimney fan. The type of isolation switch required depends on the chimney fan control system.

Type	Description	Used with controls
REP-AFB	2-pole isolation switch	EFC16, EFC35/EFC35S, Xzense, EFC21, EBC10v2
REPAFB3P	3-pole isolation switch	EFC16, EFC21
REPSW2x16	4-pole* isolation switch	EFC18, EFC21

* 3-pole with help switch

Plenumbox PLX



Example
Chimney fans and accessories not included

The plenum box is a flue gas collector for accommodating several chimney fans on a chimney head. Made of stainless steel, wall thickness 2mm, pickled. The plenum box is made for every chimney head size. Special solutions on site can thus be implemented without problems.

Type	Description
PLX-2	Plenumbox to accommodate 2 chimney fans
PLX-3	Plenumbox to accommodate 3 chimney fans
PLX-4	Plenumbox to accommodate 4 chimney fans

Installing a chimney fan

The chimney fan is installed on top of the chimney. The chimney fan is supplied as standard with adjustable location brackets, armoured power cable, a safety wire and a mineral wool mat, which ensures vibration-free operation.

When installing a fan onto a brick chimney the location brackets are fitted under the chimney fan.

If the chimney fan is to be fitted onto a steel chimney, then a flange and vibration dampers must be used instead of location brackets. The flange, which includes vibration dampers is ordered separately.

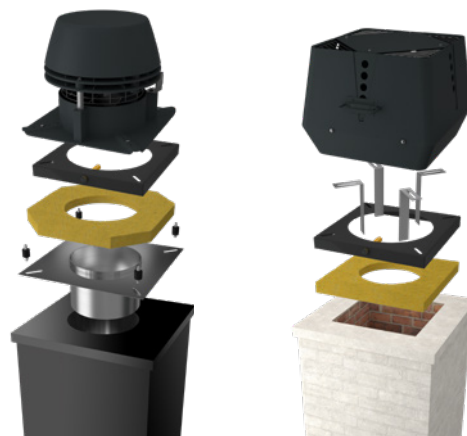

Hiding the chimney fan

Installation of **exodraft** chimney fans on top of chimneys can sometimes be difficult due to special site conditions such as listed buildings or special architectural demands. For those installations it is possible to make the fans virtually invisible.

Contact **exodraft** for assistance if such a solution is needed.

Find more about how to hide a chimney in our brochure at: www.exodraftinfo.dk/brochures/3100128-concealing-the-fan-UK.pdf

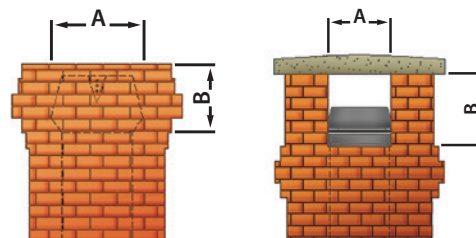

Service and maintenance



The chimney fan should be cleaned as often as needed (at least once a year) depending on the type of fire fuel.

When the fan is open, it is easy to clean it while the chimney is being swept.

Find more about how to clean the specific chimney fans, visit www.exodraft-manuals.com.

The chimney fan must always be running when there is a fire in the fireplace, stove or boiler. **exodraft** provides a two-year manufacturer's warranty. The **exodraft** warranty does not include damage caused by fire.

The image shows the top of a building with a dark brick roof and a large glass window reflecting a blue sky with white clouds. The 'exodraft' logo is mounted on the brick wall above the window. The logo consists of the word 'exodraft' in a white, sans-serif font, with a stylized red and white swoosh element above the 'o' and 'd'.A large, black 'exodraft' logo is centered on a white background. The logo features a stylized red and white swoosh above the 'o' and 'd'. A thin red horizontal line is positioned below the 'x' and 'o'.

DK: exodraft a/s

Industrivej 10
DK-5550 Langeskov
Tel: +45 7010 2234
Fax: +45 7010 2235
info@exodraft.dk
www.exodraft.dk

SE: exodraft a/s

Kalendevägen 2
SE-302 39 Halmstad
Tlf: +46 (0)8-5000 1520
info@exodraft.se
www.exodraft.se

NO: exodraft a/s

Storgaten 88
N-3060 Svelvik
Tel: +47 3329 7062
info@exodraft.no
www.exodraft.no

UK: exodraft Ltd.

24 Janes Meadow, Tarleton
GB-Preston PR4 6ND
Tel: +44 (0)1494 465 166
Fax: +44 (0)1494 465 163
info@exodraft.co.uk
www.exodraft.co.uk

DE: exodraft a/s

Niederlassung Deutschland
Soonwaldstr. 6
DE-55569 Monzingen
Tel: +49 (0)6751 855 599-0
Fax: +49 (0)6751 855 599-9
info@exodraft.de
www.exodraft.de

FR: exodraft sas

78, rue Paul Jozon
F-77300 Fontainebleau
Tel: +33 (0)6 3852 3860
info@exodraft.fr
www.exodraft.fr