



SECONDARY
HEATING

SCHIEDEL

Isokern Pumice

System chimneys & liners designed for woodburning stoves to reduce the reliance on gas central heating.



**DON'T FORGET TO REGISTER YOUR INSTALLATIONS
AND START EARNING SCHIEDEL INSTALLER REWARDS**
See inside for more details

www.schiedel.com/uk

SAP 940002642 - August 2022

Pumice – naturally better

Pumice is a natural insulator. This is the unique property that separates pumice from all other chimney materials.

The insulating properties of Pumice allow the flue gases in the chimney to quickly reach their optimum temperature enabling the heating appliance to reach its optimum performance shortly after lighting.

It also keeps the chimney warmer longer as the heat output of the appliance decreases – once again aiding performance and reducing the likelihood of condensation and soot build-up.



Pumice: is an excellent insulator, keeping flue gases warm while not transmitting heat to the outside.

The natural properties of pumice

Resistant to temperature change

Pumice has very little expansion and contraction with temperature change. This reduces the possibility of cracking and structural damage that can occur with other products.

High Insulation Properties

Pumice is a natural insulator, able to maintain the temperature of flue gases when other products have allowed the temperature to fall below the dew point.

Lightweight

Pumice is strong yet lightweight allowing one person to lift and build the chimney units.



Pumice is a natural material sourced from the Hekla Volcano in Iceland.



Pumice is strong, yet lightweight and comes in easy building blocks.

Product Description

Schiedel Isokern products can be used for new chimneys and for the refurbishment of existing chimneys. The Isokern chimney systems provide a lightweight, easily installed and versatile chimney which can be used internally or externally.

The systems are suitable for use with burning appliances in new and refurbished projects. They are ideal for Masonry, Timber Frame and Steel Frame construction. Isokern chimneys have been installed in Europe for over 60 years.

DM (DOUBLE MODULE)

Schiedel Isokern DM block system is a high quality System Chimney. The double wall system maintains flue gas temperatures while preventing heat transference to the outer casing. The separation of the inner and outer components also allows for thermal movement, reducing the risk of cracking and subsequent leaking or staining. It is simple and quick to build. The DM is available in 3 outer casing sizes - DM36, DM44 & DM54.



FLUE LINERS

The Schiedel Isokern flue liner range consists of over 15 different sizes. They can be used for newbuild, extensions and relining existing chimneys.



FIRECHESTS

The Schiedel Isokern range of firechests are supplied as flat packs. They can be easily and quickly constructed to produce a neat and pre-formed fire opening ready for finishing. The Magnum Firechest provides the opportunity to create fire openings up to 1.2m wide.



GARDEN FIREPLACE RANGE

The natural pumice gives this outdoor fireplace all the insulation needed to have a safe and spectacular focal point of any garden. The relatively small footprint also means that this can be placed against any wall in even the tiniest of gardens or yards.



DM Double Module Chimney System

When the ease of construction and maximum insulation matter then the Double Module System comes into its own. The system is designed to be quick and easy to install.

The lightweight blocks are easy to handle. The outer and inner blocks are laid at the same time but with staggered joints for safety and stability. The double layer of pumice blocks separated by an air gap maximises the chimney insulation.

The Pumice Systems are suitable for wood burning, solid fuel, oil and gas (not condensing appliances including Biomass & Pellets).

There are 3 systems covering a range of different internal diameters to meet the requirements of different appliances and uses:

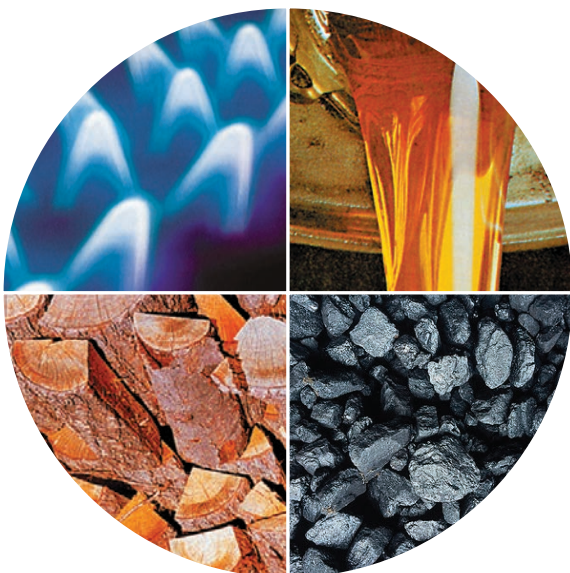

DM 36

150mm internal diameter for smaller output inserts, stoves and solid fuel/oil cookers

DM 44

180mm and 200mm internal diameters for inserts, stoves and open fires

DM 54

300mm and 345mm internal diameters for Magnum firechests and larger appliances, inserts and open fires

Unique features of the Isokern DM Chimney System

- Zero distance to combustibles on straight rendered chimneys
- Quick and easy to assemble
- Lightweight materials, easy to handle
- Highly insulating pumice for better draw and minimum heat loss
- Staggered joints for maximum safety and stability
- Air gaps between outer casing and flue prevents surface staining
- Good resistance to temperature variations gives the maximum performance for your appliance



Approvals

Isokern Pumice Double Module DM is CE Certified to EN1858 TÜV Cert no. 0036 CPR 90219 001

Isokern Pumice Chimney Liner is CE certified to EN1857 TÜV Cert no. 0036 CPR 90219 002

Isokern Magnum Firechest has been tested at the Fraunhofer Institut, Stuttgart, Cert no. P8-094/2006

CE Designation	
Double Module DM System Chimney* T450 N1 D 3 G(00)	Pumice Chimney Liner T600 N2 D 3 G



* Zero distance to combustibles on straight chimney systems with ventilated terminal. 38mm distance to combustibles on offset systems, and non ventilated systems.

DM 36 – for smaller output inserts, stoves and cookers

Available in Ø150mm internal diameter only.



FREE STANDING STOVE IN A RECESS

System includes a Stainless Steel adaptor for ease of connection between the stove and the DM Chimney.

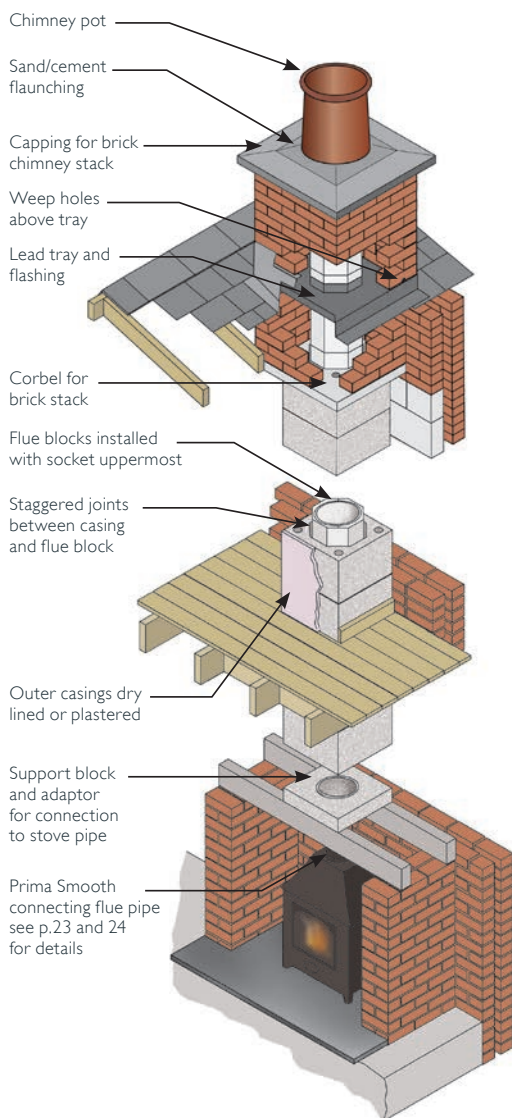

FREE STANDING STOVE WITH EXTERNAL CHIMNEY AND PREFORMED FLUE ENTRY KIT

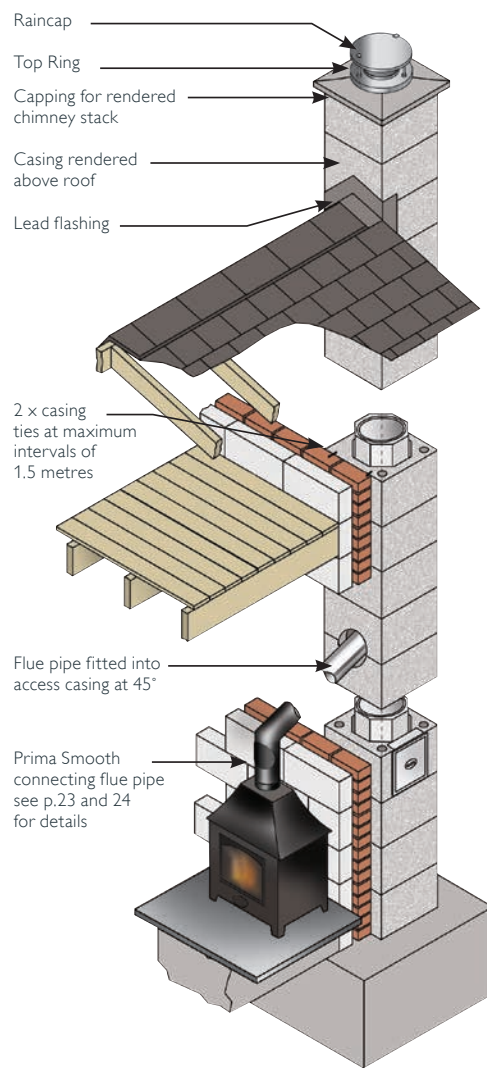

DM 36 – for smaller output inserts, stoves and cookers

		SAP Code	Description	Weight (kg)
		All dimensions are external unless otherwise stated		
		130714	360mm square casing 250mm high	15
		130712	360mm square access casing 250mm high (150mm i/d access hole)	13
		130713	360mm square casing & soot door 250mm high	18
		130709	DM36 45° flue entry kit (four parts) 500mm high	42
		126363	150mm i/d 255 x 255 starter flue block 125mm high	4
		126369	150mm i/d 255x255 flue block 250mm high	8
		126368	150mm i/d 255x255 access flue block 500mm high (177mm i/d access hole)	16
		130715	570mm square corbel for brickwork 75mm high	32
		130710	490mm square capping - render	13
		130711	690mm square capping - brickwork	31
		126378	150mm i/d 360 x 435 offset block (86mm, 30° offset) 150mm high (allow 38mm distance to combustibles on offset chimneys)	25
		130716	150mm i/d 360 square support block 100mm high	15
		126373	150mm i/d (205mm o/d) stainless steel adaptor	
		126357	125-150mm i/d (205mm o/d) stainless steel decreaser adaptor	
		130732	Raincap (with fixing rods for top ring)	
		135070	Top Ring (for ventilation)	

DM 44 – for inserts, stoves and small open fires

Available in internal diameters Ø180mm and Ø200mm.
Both inner liners fit into the same external block size.



INSET FIRE

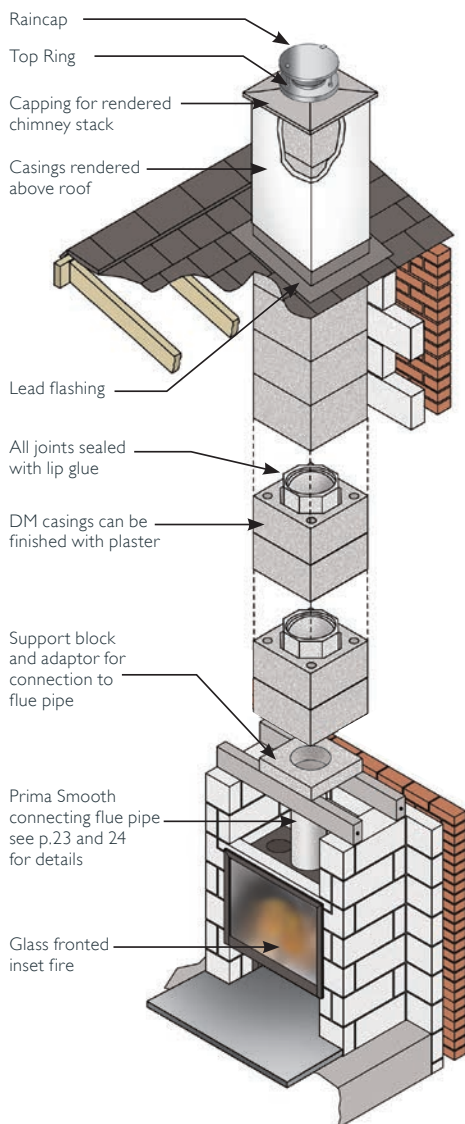

OPEN FIRE USING STANDARD FIRECHEST

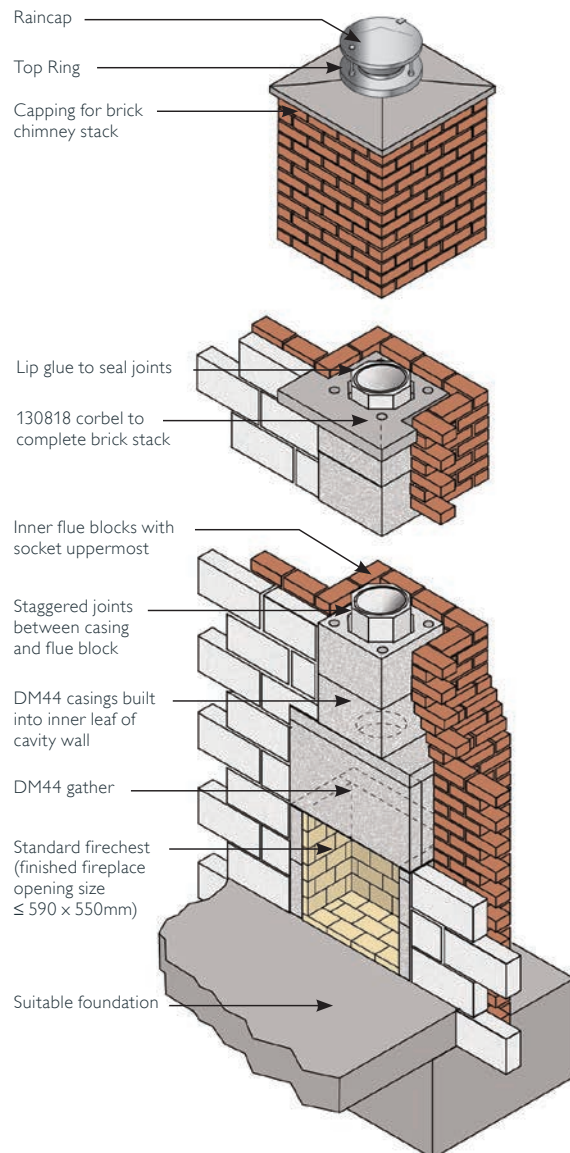

DM 44 – for inserts, stoves and small open fires

		SAP Code	Description	Weight (kg)
		All dimensions are external unless otherwise stated		
		130727	440mm square casing 300mm high	30
		130725	440mm square access casing 300mm high (220mm i/d access hole)	29
		130726	440mm square casing & soot door 300mm high	36
		130719	440mm 180mm i/d 45° flue pipe entry kit (4 parts) 600mm high	86
		130722	440mm 200mm i/d 45° flue pipe entry kit (4 parts) 600mm high	84
		130720	180mm i/d 310 x 310 starter flue block 150mm high	8
		127684	200mm i/d 310 x 310 starter flue block 150mm high	7
		127068	180mm i/d 310 x 310 flue block 300mm high	15
		127683	200mm i/d 310 x 310 flue block 300mm high	14
		130717	180mm i/d flue 310 x 310 access block 600mm high	28
		127682	200mm i/d flue 310 x 310 access block 600mm high	26
		130728	650mm square corbel for brickwork 75mm high	40
		130235	650 x 560mm offset corbel for brickwork 75mm high	34
		130818	740mm T corbel for external brickwork 75mm high	47
		130723	570mm square capping for render	18
		130724	820mm square capping for brickwork	44
		135082	180mm i/d 440 x 500 offset block (56mm, 30° offset) 100mm high	22
		130718	180mm i/d 440 x 500 offset block (86mm, 30° offset) 150mm high	32
		127686	200mm i/d 440 x 500 offset block (56mm, 30° offset) 100mm high	20
		127687	200mm i/d 440 x 500 offset block (86mm, 30° offset) 150mm high (Allow 38mm distance to combustibles on offset chimneys)	30
		130721	180mm i/d 440mm square support block 100mm high	22
		130730	200mm i/d 440mm square support block 100mm high	20
		127691	200mm i/d (255mm o/d) stainless steel adaptor	
		127671	150-200mm i/d (255mm o/d) stainless steel decreaser adaptor	
		127672	175-200mm i/d (255mm o/d) stainless steel decreaser adaptor	
		130732	Raincap (with fixing rods for top ring)	
		130675	Top Ring (for ventilation)	

DM 54 – for larger open fires and appliances

Available in internal diameters Ø300mm and Ø345mm.
Both inner liners fit into the same external block size.



LARGE FIRE OPENING CREATED WITH MAGNUM FIRECHEST

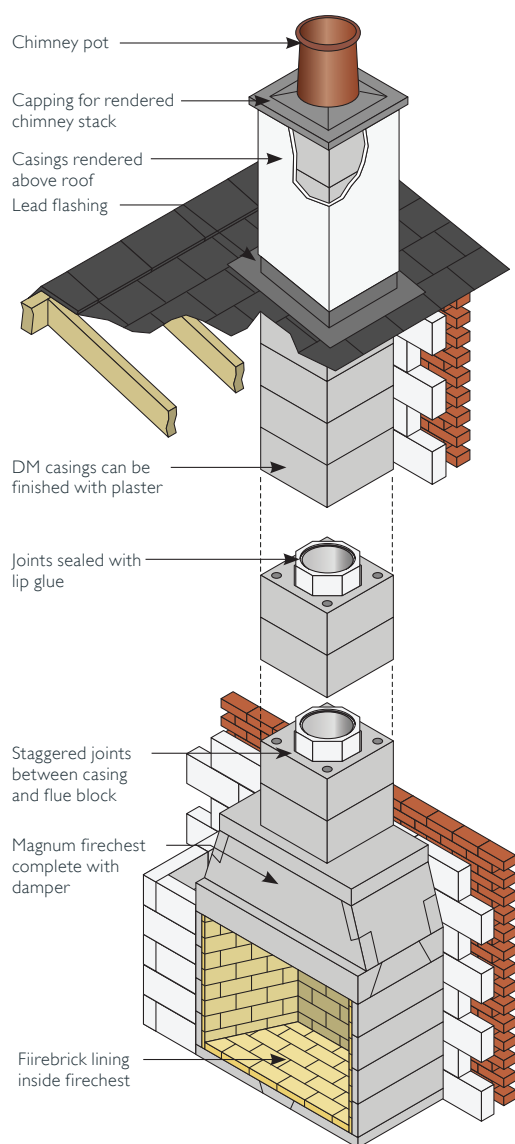

DM 54 – for larger open fires and appliances

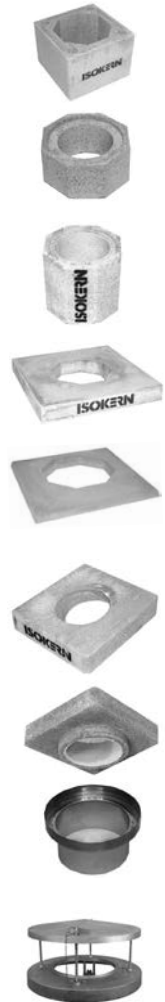

SAP Code	Description	Weight (kg)
All dimensions are external unless otherwise stated		
130708	545mm square casing 300mm high	40
129031	300mm i/d 420 x 420 starter flue block 150mm high	11
129093	345mm i/d 420 x 420 starter flue block 150mm high	11
129033	300mm i/d 420 x 420 flue block 300mm high	22
129094	345mm i/d 420 x 420 flue block 300mm high	22
130735	800mm square corbel for brickwork 75mm high	57
130733	670mm square capping for render	20
130734	950mm square capping for brickwork	46
129038	300mm i/d 545 x 635 offset block (86mm, 30° offset) 150mm high	44
129092	345mm i/d 545 x 635 offset block (86mm, 30° offset) 150mm high (allow 38mm distance to combustibles on offset chimneys)	40
129043	300mm i/d 545mm square support block 100mm high	30
129039	300mm i/d (365mm o/d) stainless steel adaptor	
130732	Raincap (with fixing rods for top ring)	
135093	Top Ring (for ventilation)	

DM Accessories



SAP Code	Description	Weight (kg)
All dimensions are external unless otherwise stated		
146432	1500 x 215 x 70mm support lintel Max load (per pair) 1650kg	51
130689	Stainless steel casing wall tie	
130771	Lip glue (5kg)	5
102629	1m reinforcement rod 12mm diameter	1

Typical DM Installation Detail

FOUNDATIONS

Construction begins by providing a suitable foundation and constructional hearth in accordance with Building Regulations and site requirements.

OPEN FIRE OPTION

Bed the base plate of the firechest onto a suitable foundation/constructional hearth in accordance with Building Regulations and at the level required on site using Isokern lip glue.

Install the firechest using lip glue making sure all elements are level. 100mm of brick/blockwork must be built around the sides and back of the firechest to comply with Building Regulations. The inside of the firechest must be finished with a suitable fireback or firebrick slips.

Install the gather using lip glue making sure all the elements are level. The front face of the gather can be finished with plasterboard, rendered or clad in masonry. Lintels may be required above the gather to help carry the brick or blockwork. The maximum loading capacity of the ISOKERN firechest and gather is 2500kg.

OPEN FIRE OPTION

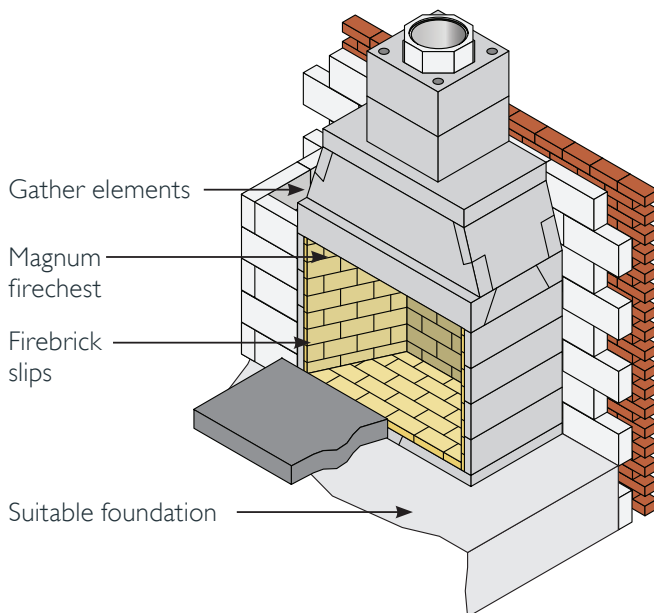

STOVE IN RECESS OPTION

Pre-stressed lintels or a suitable cast-in-situ concrete slab must be provided above the stove recess, please make sure they are strong enough to carry the load (see appropriate Isokern DM drawing for aperture size). It is recommended to have a minimum of 600mm of stove flue pipe before connecting to the support block.

The support block is bedded onto the lintels using a weak mix mortar. A stainless steel adaptor is used to create a positive connection from the support block to the stove flue pipe (fibre rope should be used to create a seal).

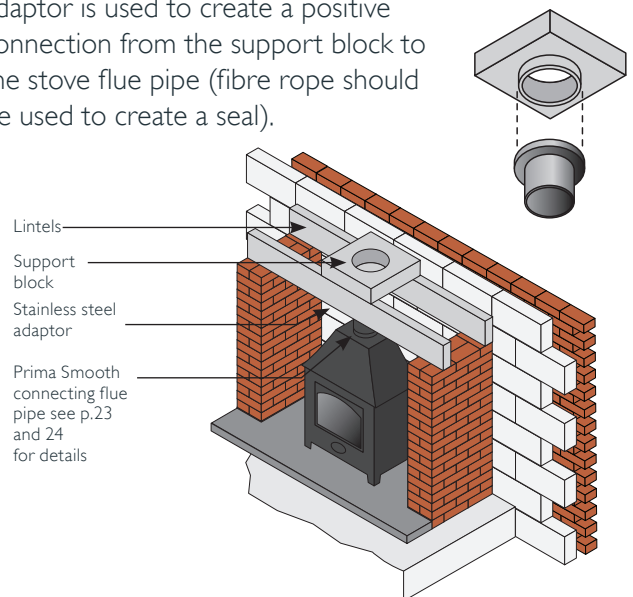

FREE STANDING STOVE OPTION

A soot door casing and access flue block must be used below the flue pipe entry. The DM 45° access kit is then used for the connecting flue pipe. A suitable wall sleeve must be used to seal the cavity wall. Any combustible insulation within the wall must then be kept away from the single wall connecting flue pipe by at least 1.5 x its diameter. Fibre rope is used to seal between the flue pipe and wall sleeve, a suitable trim collar can be used to finish the inner wall surface.

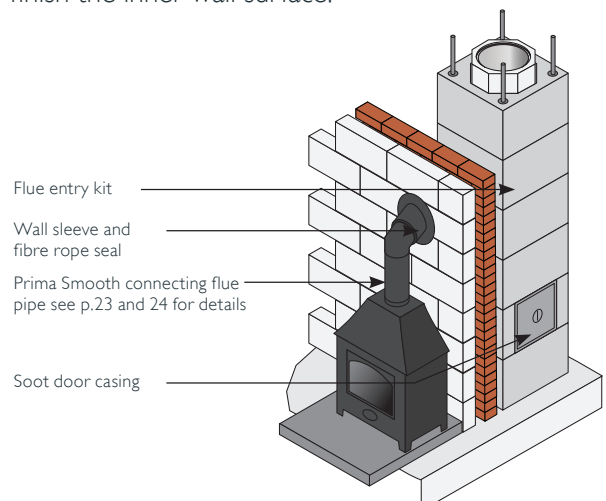

Typical DM Installation Detail

CHIMNEY CONSTRUCTION

Bed the first outer casing using lip glue making sure the rebate (raised lip) is uppermost. The starter flue block is then put inside the casing bedded with lip glue. The socket on the starter flue block must be uppermost and the air gap between the starter flue and the casing should be kept clear. The finished lip glue joints should be 2-3mm thick, a special bag is provided for ease of application and the lip glue should be applied in 12-15 mm beads.

HOW TO USE LIP GLUE

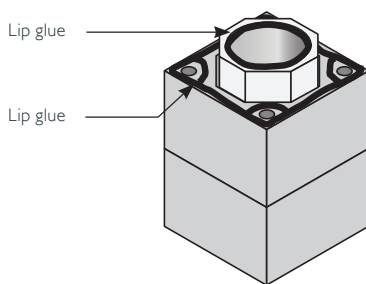

Offset blocks if required must be glued together with lip glue and be fully supported. Please note a chimney should be built straight wherever possible. A starter flue block will be required above the offset blocks to stagger the joints between the outer casing and inner flue blocks.

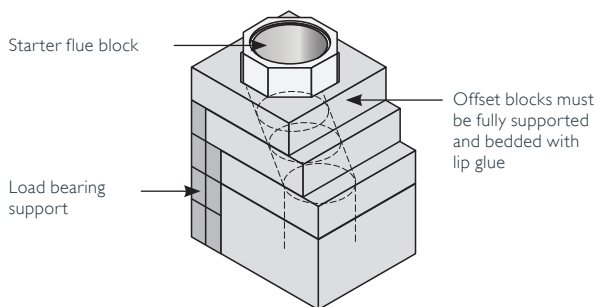

Casings and flue blocks are added using lip glue for all joints. Ensure the air gap between the inner flue and outer casing remains clear. The outer surface of the casings to be finished with plasterboard on dabs or plaster. The side that faces the wall does not need an external finish.

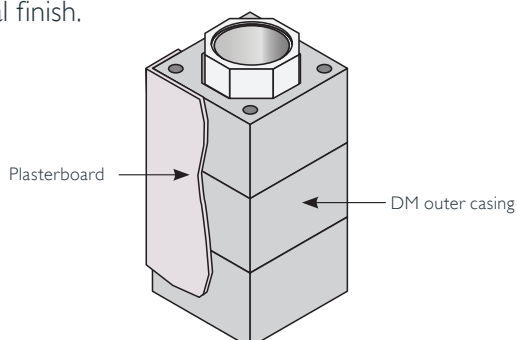

On a rendered stack with a top ring fitted (see p.12 for example), where a straight chimney passes through a floor or roof, zero mm distance to combustibles can be applied. A sliding joint is made using mineral wool or similar non-combustible material. In all other cases, 38mm clearance must be maintained between the outer face of the chimney and any structural timber or combustible material. Floor boards, skirting boards, dado rails and other non-structural components may, however, be in contact with the chimney.

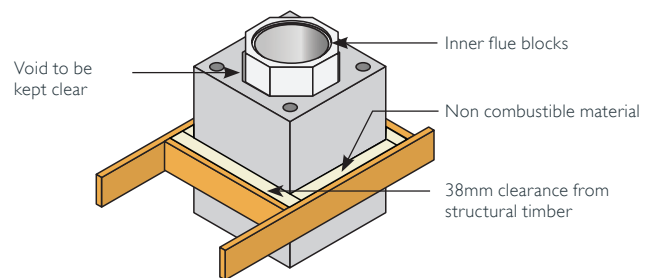

External chimneys must be tied to the structure at maximum intervals of 1.5m and at the point where it departs from the roof using 2 x suitable stainless steel wall ties. These are fitted into the outer casing joints. They are not always required for internal chimneys. Please consult the Isokern technical office.

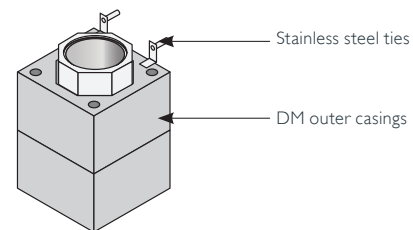

High tensile steel reinforcement rods will be required for all chimneys with a height that exceeds 1.4m above the roof line, 1.1m if the wind speed exceeds 44ms. These rods are available from Isokern and must be grouted (1:3 cement/sand) into the holes provided in the outer casings. You must start the rods at least the same height below the roof as what's above, please check with our technical department.

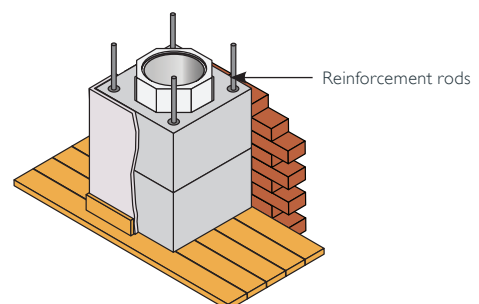

Typical DM Installation Detail

RENDERED STACK OPTION

Code 4 lead flashing to be fitted at roof level as per Building Regulations. We recommend that you scorch a 5-10mm deep channel into the outer surface of the casings and fold in the top edge of the flashing.

Finish the outer surface of the casings above the roof with 2 part waterproof render. The recommended mix is 1:2:5-6 cement:lime:sand for the undercoats. 1:2:8-9 cement:lime:sand for the final coat. The number of coats required will depend upon the degree of exposure, generally a two coat mix is acceptable. The mix may vary due to climate conditions, the thickness of any one coat should not exceed 15mm, and each subsequent coat should be reduced by approximately 3mm. Isokern concrete capping for render to be lip glued onto the last casing.

RENDERED STACK

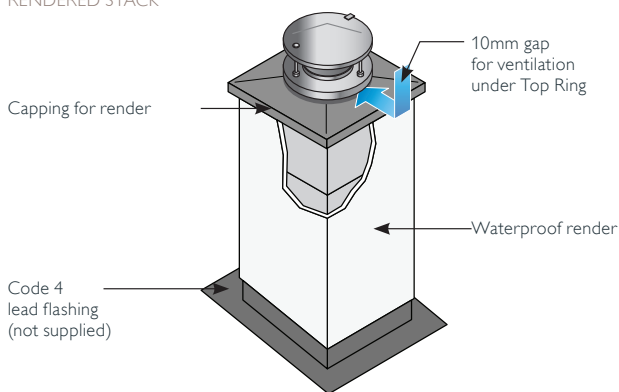

BRICK STACK OPTION

To take brick or stonework externally a corbel is fitted just below the roof. Use trusses and trimmers to brace the cladding as it passes through the roof.

Code 4 lead tray with 50mm upstands and stepped flashing to be fitted in accordance with Building Regulations. A 50mm upstand should be fitted tight to the outside of the flue block and where possible turned in by approx 10mm. Lead trays should be coated with bituminous paint where it is in contact with mortar. The D.P.C. tray should be fitted at least 150mm above the lowest point of intersection with the roof. Weep holes should be provided at the front of the stack above the tray for water drainage.

Casings can be deleted above the corbel if stack height is less than 1.4m above the roof.

TERMINATION

Raincap - Ventilated Option - (Installation with 0 distance to combustibles for straight rendered chimneys only). Take

BRICKWORK STACK

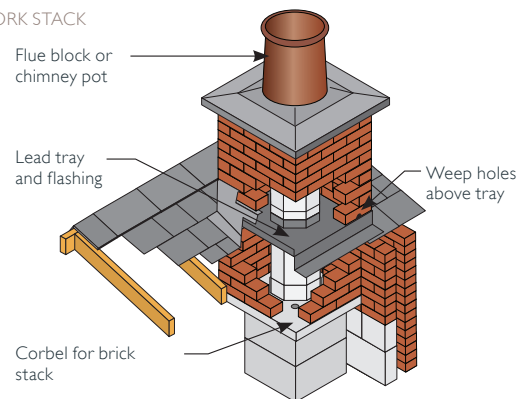

the last flue block up through the capping, do not fill the gap between the flue block and capping. Push fit the aluminium top ring onto the flue block and make sure there is a 10mm air gap between the outer edge of the ring and the capping. The flue block may need cutting to suit.

Chimney Pot Option - This option always requires a 38mm distance to combustibles from the outside of the block. Fit a chimney pot at least 75mm down into the capping and flaunch with 1:3 cement and sharp sand to seal around. This option is not possible if 0 distance to combustibles is required.

AFTER COMPLETION

After installation is complete tests and checks should be carried out in accordance with document J of the Building Regulations. A chimney notice plate must be completed and permanently fixed in the dwelling, ideally near the electrical consumer unit. The checklist and notice plate are available from Schiedel Isokern.

USE AND MAINTENANCE

The chimney should be left for at least 72 hours before use, then start only with small fires for the first week and gently increase thereafter.

The chimney should be swept at least twice a year, once before the heating season and once after the heating season. You may need to sweep during the heating season depending upon use. The brush should be a medium density polypropylene bristle type and should be the same diameter as the flue. Steel brushes must not be used to sweep the Isokern pumice flues. Always follow the appliance manufacturer's operating instructions. Always burn approved fuels or dry seasoned wood. Avoid burning unseasoned wood and slow burning of solid fuels as this can produce excessive soot and condensation which in turn cause soot fires and damage. If correctly installed, operated and maintained these systems could last the life of the dwelling.

Liner System – for new and existing chimneys

The pumice liner system comes in a range of 15 diameters from 150mm to 1000mm with T Liners, Liner Support Blocks, and Adaptors for ease of connection to the appliance.

The insulated flue liner for traditional build

Suitable for use with inserts, stoves, open fires and cookers burning wood, solid fuel, oil or gas (not condensing appliances including Biomass & Pellets).

- Lightweight materials, easy to handle
- Highly insulating pumice for better draw and minimum heat loss
- 600mm and 1000mm lengths mean fewer joints and fast to install
- 15 flue sizes available
- Good resistance to temperature variations gives the maximum performance for your appliance



INSET FIRE

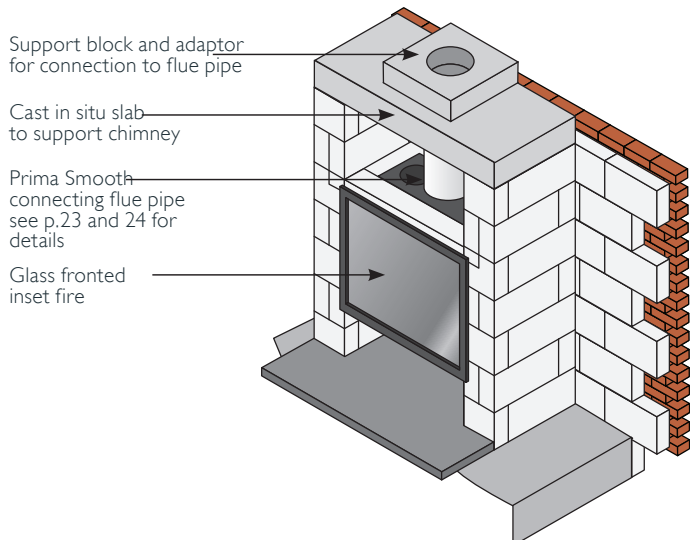
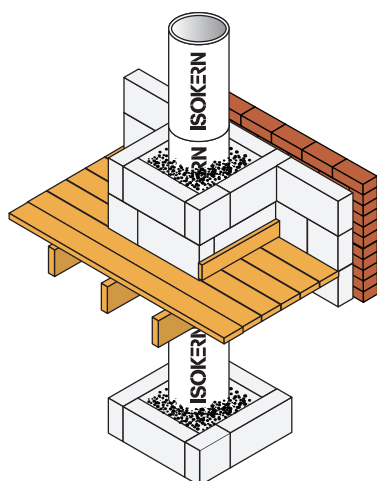

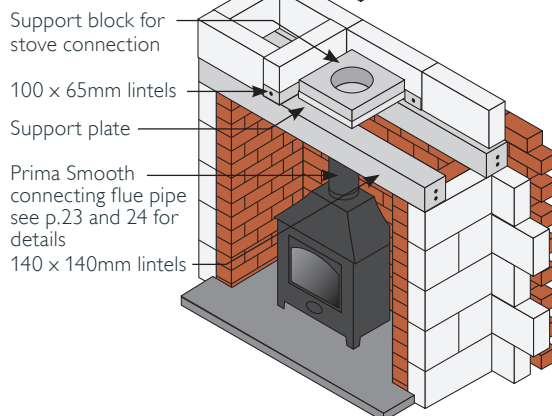
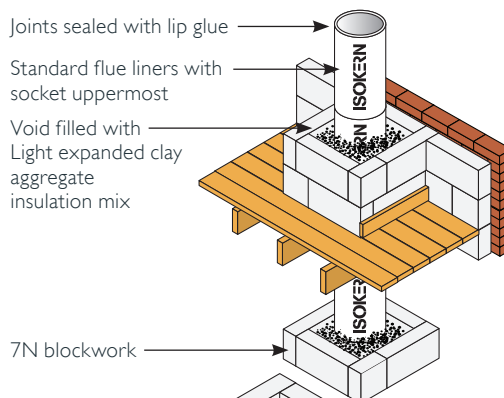
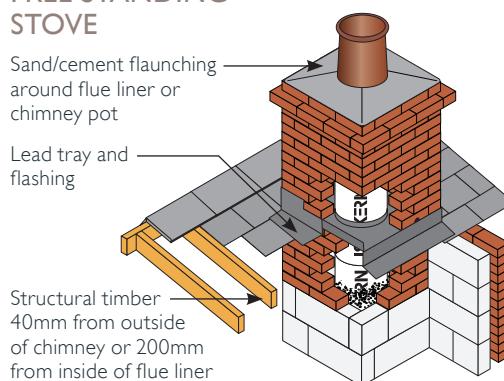

FREE STANDING STOVE





DOWNLOADABLE DRAWINGS AVAILABLE FROM OUR WEB SITE

WWW.SCHIEDEL.COM/UK

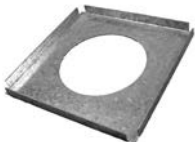
Liners and Accessories

SAP Code	Description	Weight (kg)
All dimensions are external unless otherwise stated		
Round Liners		
	126372 150mm i/d 600mm high rebated liner (200mm o/d)	8
	126498 175mm i/d 600mm high rebated liner (235mm o/d)	11
	127685 200mm i/d 600mm high rebated liner (250mm o/d)	12
	127715 225mm i/d 600mm high rebated liner (285mm o/d)	14
	128546 250mm i/d 600mm high rebated liner (310mm o/d)	16
	129036 300mm i/d 600mm high rebated liner (360mm o/d)	19
	129360 350mm i/d 600mm high rebated liner (416mm o/d)	27
	129567 400mm i/d 1000mm high rebated liner (470mm o/d)	50
	129738 450mm i/d 1000mm high rebated liner (530mm o/d)	60
	129927 500mm i/d 1000mm high rebated liner (590mm o/d)	70
	130142 600mm i/d 1000mm high rebated liner (706mm o/d)	100
Collars		
	126361 150mm steel collar	
	126494 175mm steel collar	
	127673 200mm steel collar	
	127705 225mm steel collar	
	128533 250mm steel collar	
	129021 300mm steel collar	
	129356 350mm steel collar	
Support Lintel		
	146431 1500 x 140 x 140mm support lintels Max load (per pair) 3250kg	71
	169330 600 x 100 x 65mm support lintels	9
Support Plates (for supporting liners and support blocks)		
	127694 210mm i/d 340mm square 4mm thick (fits 150mm support blocks)	3
	128549 255mm i/d 360mm square 4mm thick (fits 175mm and 200mm support blocks)	3

Liners and Accessories

SAP Code	Description	Weight (kg)
All dimensions are external unless otherwise stated		
Liner Support Blocks (for connection to single wall connecting flue pipe)		
	126366 150mm i/d 310mm square 75mm high	7
	126483 175mm i/d 350mm square 75mm high	8
	127340 200mm i/d 350mm square 75mm high	8
	130731 225mm i/d 440mm square 100mm high	20
	128548 250mm i/d 440mm square 100mm high	20
	129043 300mm i/d 545mm square 100mm high	30
T Liners		
	126376 150mm i/d 45° rebated T liner 600mm high	15
	126500 175mm i/d 45° rebated T liner 600mm high	20
	127695 200mm i/d 45° rebated T liner 600mm high	22
	126375 150mm i/d 90° rebated T liner 600mm high	15
Light expanded clay aggregate		
	130769 50 litre (0.05m ³)	approx. 19
Lip Glue		
	130771 Lip glue (5kg)	5

Liners and Accessories



SAP Code	Description	Weight (kg)
<small>All dimensions are external unless otherwise stated</small>		
Liner Bends		
126364	150mm i/d 15° rebated bend	4
126365	150mm i/d 30° rebated bend	5
126367	150mm i/d 45° rebated bend	6
126495	175mm i/d 15° rebated bend	5
126496	175mm i/d 30° rebated bend	6
126497	175mm i/d 45° rebated bend	8
127679	200mm i/d 15° rebated bend	5
127680	200mm i/d 30° rebated bend	6
127681	200mm i/d 45° rebated bend	8
127706	225mm i/d 15° rebated bend	7
127707	225mm i/d 30° rebated bend	8
127708	225mm i/d 45° rebated bend	9
128542	250mm i/d 15° rebated bend	8
128531	250mm i/d 30° rebated bend	9
128532	250mm i/d 45° rebated bend	10
129015	300mm i/d 15° rebated bend	10
129016	300mm i/d 30° rebated bend	11
131819	300mm i/d 45° rebated bend	12
129354	350mm i/d 15° rebated bend	13
129355	350mm i/d 30° rebated bend	14
131820	350mm i/d 45° rebated bend	16
<small>Larger diameter bends available on request.</small>		
Stainless Steel Adaptors with Sealing Rope (for connection to support block)		
126373	150mm i/d (205mm o/d)	
126499	175mm i/d (235mm o/d)	
127691	200mm i/d (255mm o/d)	
127719	225mm i/d (290mm o/d)	
128547	250mm i/d (315mm o/d)	
129039	300mm i/d (365mm o/d)	
Stainless Steel Increaser Adaptors with Sealing Rope (for connection to support block)		
126357	125-150mm i/d (205mm o/d)	
126493	150-175mm i/d (235mm o/d)	
127671	150-200mm i/d (255mm o/d)	
127672	175-200mm i/d (255mm o/d)	
127704	200-225mm i/d (290mm o/d)	
Stainless Steel Adaptors with Sealing Rope (for connection to T liners)		
125453	125-150mm i/d (210mm o/d)	
126358	150mm i/d (210mm o/d)	
146412	150-175mm i/d (240mm o/d)	
146413	175mm i/d (240mm o/d)	



Liners and Accessories



SAP Code	Description	Weight (kg)
All dimensions are external unless otherwise stated		
Access Blocks		
126362	150mm i/d 215mm square 205mm high rebated access block	5
127678	200mm i/d (also for 175mm) 280mm square 280mm high rebated access block	12
Soot Door		
142837	Double soot door 265 x 395mm	2
Insulated Plug		
142599	Insulated plug (glue to access blocks)	4
Chimney Pots		
Terracotta		
126371	150mm i/d roll top terracotta 450mm high	14
127341	200mm i/d roll top terracotta 450mm high	16
127713	225mm i/d roll top terracotta 300mm high	12
127714	225mm i/d roll top terracotta 450mm high	18
128543	250mm i/d roll top terracotta 450mm high	19
129035	300mm i/d roll top terracotta 450mm high	26
129359	350mm i/d roll top terracotta 450mm high	32
Buff		
126370	150mm i/d roll top buff 450mm high	14
130697	200mm i/d roll top buff 450mm high	16
127702	225mm i/d roll top buff 300mm high	12
127711	225mm i/d roll top buff 450mm high	18
128544	250mm i/d roll top buff 450mm high	19
129034	300mm i/d roll top buff 450mm high	26
129358	350mm i/d roll top buff 450mm high	32
Topguards		
Terracotta		
130737	Topguard terracotta 150-250mm i/d	2
130738	Topguard terracotta 300mm i/d	2
130739	Topguard terracotta 350mm i/d	2
Buff		
130742	Topguard buff 150-250mm i/d	2
130740	Topguard buff 300mm i/d	2
130741	Topguard buff 350mm i/d	2
Notice Plate		
130696	Chimney notice plate	
Smoke Pellets		
130817	Smoke pellets (6 per tube)	

Typical Liner Installation Detail

Construction begins by providing a suitable foundation and constructional hearth in accordance with Building Regulations and site requirements.

STOVE IN RECESS OPTION

Our pre stressed lintels must be installed above the fireplace recess, for this method a support plate is required under the support block. Alternatively a suitable cast-in-situ concrete slab lintel can be created above the fireplace recess. (See Isokern standard drawings for hole size depending on diameter of chosen flue).

The support block is bedded onto the slab lintel using weak mix mortar. A stainless steel adaptor is used to connect from the support block to the stove flue pipe. This adaptor is pushed up onto the support block spigot (fibre rope should be used to create a seal). It is recommended to have a minimum of 600mm length of flue pipe before connecting to the chimney.

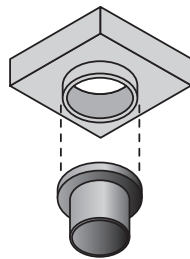

STOVE IN RECESS OPTION

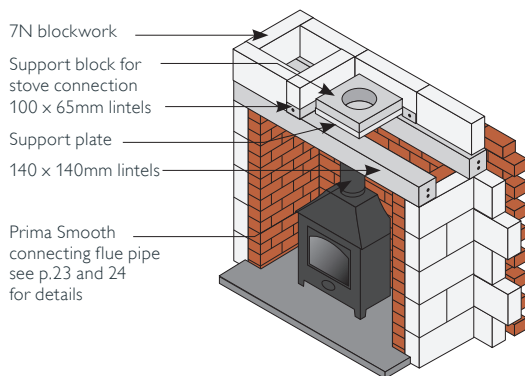

FREE STANDING STOVE OPTION

A soot door must be provided below the flue pipe entry to allow for inspection and removal of soot and debris. A suitable wall sleeve is to be used to seal the cavity wall. Any combustible insulation within the wall must be kept away from the single skin connecting flue pipe by at least 1.5 x its diameter.

A stainless steel adaptor is fitted to the Isokern T Liner with the fibre tape supplied. The flue pipe is a push fit over the spigot on the adaptor. Seal off the gap between the flue pipe and wall sleeve with fire proof rope and closing plate.

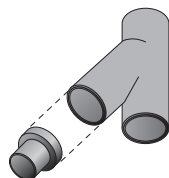

FREE STANDING STOVE OPTION

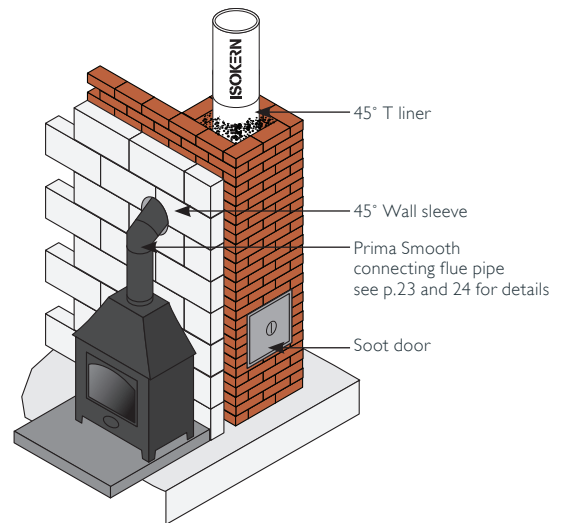

OPEN FIRE OPTION

Install the firechest onto the constructional hearth using lip glue making sure all elements are level. 100mm of brick or blockwork must be built around the sides and back of the firechest to comply with Building Regulations. The inside of the firechest must be finished with a suitable fireback or firebrick slips.

Install the gather using lip glue making sure all elements are level. The front face of the gather can be finished with plasterboard, rendered or clad in masonry. Lintels may be required above the gather to help carry the brick or blockwork. The maximum loading capacity of the Isokern firechest and gather is 2500kg.

OPEN FIRE OPTION

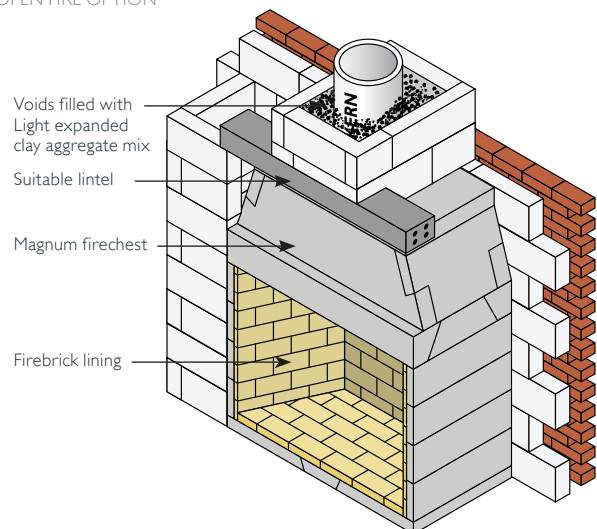

Typical Liner Installation Detail

ALL OPTIONS

The flue liners are installed socket uppermost and sealed with Isokern lip glue. Finished lip glue joints should be 2-3mm thick. A special bag is provided for ease of application and the lip glue should be applied in 12-15mm beads. Remove any excess glue to maintain a smooth surface. Clad the liners with a minimum of 100mm thick brickwork or medium density (7kN) blockwork. A minimum thickness of 15mm Light expanded clay aggregate insulation must be installed between the liners and masonry. Mix 20 parts to 1 part opc cement and a small amount of water. Make sure it is well mixed before using.

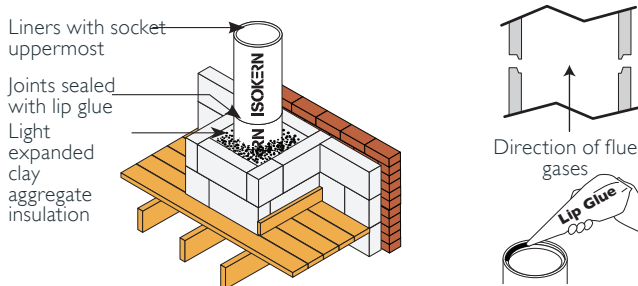

If bends are required in the chimney make sure adequate support is provided and always backfill with light expanded clay aggregate insulation mix. Liners can be cut between bends to achieve a required offset distance. A steel collar as well as lip glue must be used for any cut joints. A maximum of 2 complete offsets (4 bends) are allowed per chimney and the angle must not be greater than 45° from the vertical.

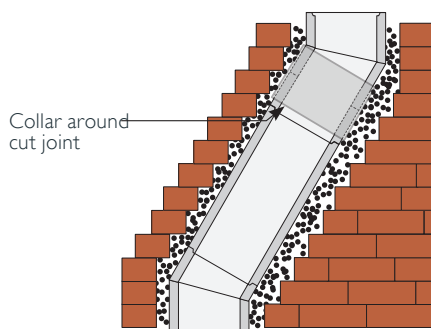

You must provide adequate clearance from combustible material in accordance with Building Regulations. Combustible materials must be 200mm from the inner surface of flue liner or 40mm from the outside of the masonry chimney unless it is a floorboard, skirting board, dado or picture rail, mantel-shelf or architrave.

Fit appropriate lead dpc's and flashings in accordance with the relevant regulations. Isokern recommend that the lead tray should be dressed up the outside of the flue liners to avoid a weak joint. Weep holes should be provided above the tray for moisture drainage.

Terminate the chimney to the correct height in accordance with document J of the Building Regulations. The chimney can be finished by flaunching (1:3 cement/ sharp sand) either around the Isokern flue liner or a suitable chimney pot. Approved rain caps can be used to help prevent water entering the flue.

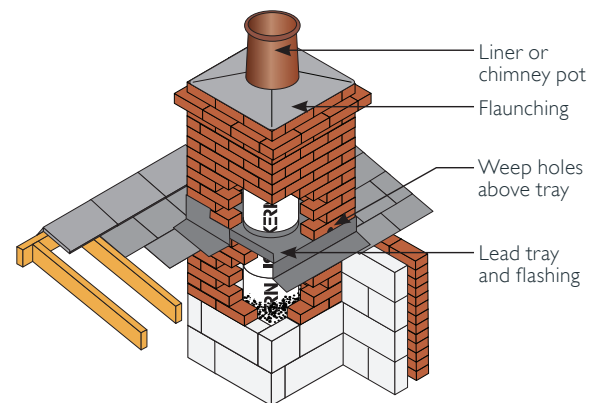

AFTER COMPLETION

After installation is complete tests and checks should be carried out in accordance with document J of the Building Regulations. A chimney notice plate must be completed and permanently fixed in the dwelling, ideally near the electrical consumer unit. The checklist and notice plate are available from Schiedel Isokern.

USE AND MAINTENANCE

The chimney should be left for at least 72 hours before use, then start with only small fires for the first week and gently increase thereafter.

The chimney should be swept at least twice a year, once before the heating season and once after the heating season. You may need to sweep during the heating season depending upon use. The brush should be a medium density polypropylene bristle type and should be the same diameter as the flue. Steel brushes must not be used to sweep Isokern pumice flues.

Always follow the appliance manufacturer's operating instructions. Always burn approved fuels or dry seasoned wood. Avoid burning unseasoned wood and slow burning of solid fuels as this can produce excessive soot and condensation which can in turn cause soot fires and damage. If correctly installed, operated and maintained these systems could last the life of the dwelling.

Firechests

The ideal solution for creating open fires. The finished appearance is down to individual taste using one of the many fireplace surrounds on the market.

The Schiedel Isokern firechest complements the Isokern chimney systems which are designed to create a complete system, avoiding many of the variable factors that lead to draught problems and smoky fireplaces.

The Isokern firechest range is cast using lightweight, highly insulating pumice. The components interlock like pieces of a three dimensional jigsaw to form a sturdy, robust fireplace recess and gather. The joints are sealed using lip glue jointing compound. Starting from a suitable foundation and constructional hearth, assembly of the

complete firechest and gather could take less than one hour.

The range includes firechests with fire opening widths from 500 to 1250mm. Each firechest is packed on a pallet with detailed assembly instructions. The firechest is load bearing and will carry up to 2600kg of chimney above, although you may exceed this weight with the use of additional lintels.

THE MAGNUM FIRECHEST RANGE

The Magnum Firechest range has been designed to maximise the burning efficiency of wood in an open fire. The specially shaped fire chamber facilitates the efficient burning of wood logs to give efficiencies from 41% to 45%, depending on the model chosen. The firechests are tested to EN13229.

DAMPER

A flue damper is available in the Magnum range of firechests. In wood burning installations the flue damper can be used to control the draft in the flue and avoid excessive heat loss when the fireplace is not being used. This is reflected in the SAP calculation for Document L. The inclusion of the damper will halve the chimney ventilation rate in the SAP calculation. It must not be installed with gas fires.



MAGNUM FIRECHEST WITH DM SYSTEM CHIMNEY

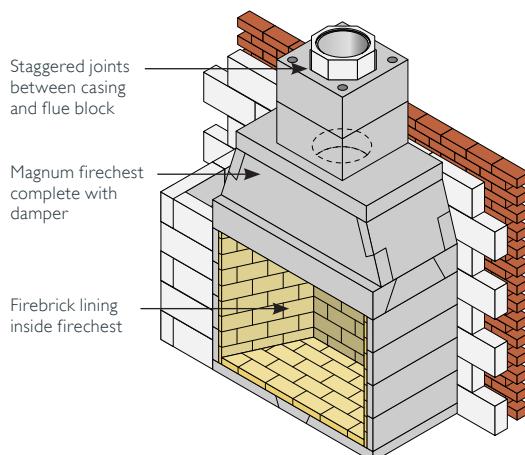

MAGNUM FIRECHEST WITH PUMICE LINERS

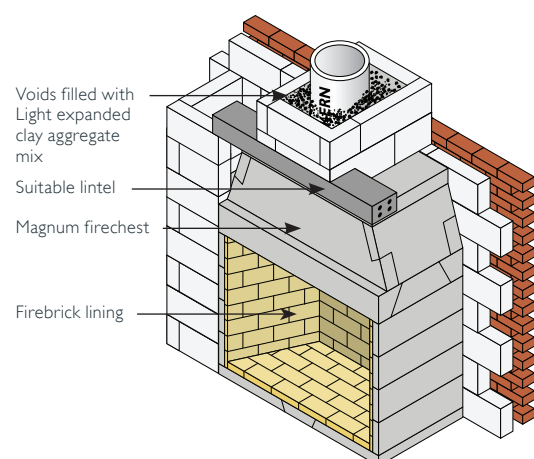

DOWNLOADABLE DRAWINGS AVAILABLE FROM OUR WEB SITE

WWW.SCHIEDEL.COM/UK

Firechests



SAP Code	Model	Opening Width (mm)	Opening Height (mm)	Ext. Width (mm)	Ext Height (mm)	Ext. Depth (mm)	Weight (kg)
Magnum Firechests							
130773	500	510	540	685	1540	440	390
129371	950	990	960	1090	1761	710	715
129568	1100	1130	960	1230	1761	710	790
129767	1200	1246	960	1346	1761	710	845
Magnum 500 Inside Flue diameter 200mm Magnum 950 - 1200 Inside Flue diameter 350mm							
Standard Firechests							
130820		690	660	850	660	450	100



SAP Code	Model	Inside Flue Dia. (mm)	Internal Width (mm)	Ext. Width (mm)	Ext Height (mm)	Ext. Depth (mm)	Weight (kg)
Manor Gatherers							
133463	900 Centre Hole	350	933	1086	525	640	140
135267	900 Offset Hole	350	933	1086	525	640	140
135280	1150 Centre Hole	350	1191	1350	930	640	268
135279	1150 Offset Hole	350	1191	1350	930	640	268



Pumice Gatherers							
130822	Liner	225	690	850	600	450	100
130729	DM44	200	690	850	600	450	100



Concrete Gatherers							
130699	C16	200/225	600	800	225	450	110
131200	C17	250	800	1000	300	550	130
131201	C18	300	800	1000	300	550	138



SAP Code	Description	Weight (kg)
Firebricks and Firebacks		
112562	Firebrick 230 x 114 x 25mm buff	1.6
115281	Firebrick 230 x 114 x 50mm buff	2.8
130753	Firebrick mortar	20
129735	450mm milner scored clay fireback	42.5

Ignis-Protect

Designed specifically for Air Tight, Energy Efficient and Timber Framed Buildings

Use of 90° Ignis-Protect System in accordance with BS EN 15287-1 Acceptable alternative methods of connection methods

Where a horizontal connecting flue of more than 150mm is required to connect a solid fuel fired appliance to a chimney, an installation method as per the examples below may be used provided the following criteria is met:

- The maximum length of horizontal connecting flue pipe does not exceed 450mm
- A Defra exempt appliance or an appliance, which is limited to burning authorised smokeless fuel only, is installed
- A calculation according to BS EN13384-1 has indicated safe operation of the proposed configuration, and the results of the calculation are left with the householder along with the appliance installation instructions
- The appliance manufacturer agrees in writing to the proposed configuration
- The chimney manufacturer agrees in writing to the proposed configuration
- The total length of single wall connecting flue pipe is not more than 1.5m
- The appropriate distances to combustible materials from both the appliance and the connecting flue pipe are maintained.



Ignis-Protect

SAP Code	Thickness (mm)	Height (mm)	Width (mm)	Pallet Quantity
Ignis-Protect 90° Version				
101841	150	700	565	12
101842	200	700	565	9
101843	250	700	565	6
101844	300	700	565	4
101845	350	700	565	4
101846	400	700	565	2
Ignis-Protect 45° Version				
149530	100	1020	565	18
149531	150	1020	565	12
149532	200	1020	565	9
149533	250	1320	565	6
149534	300	1320	565	4
149535	350	1320	565	4
149536	400	1320	565	2
144032	450	1320	565	2
144033	466	1320	565	2
144034	500	1320	565	2

TYPICAL INSTALLATION OF 45° VERSION

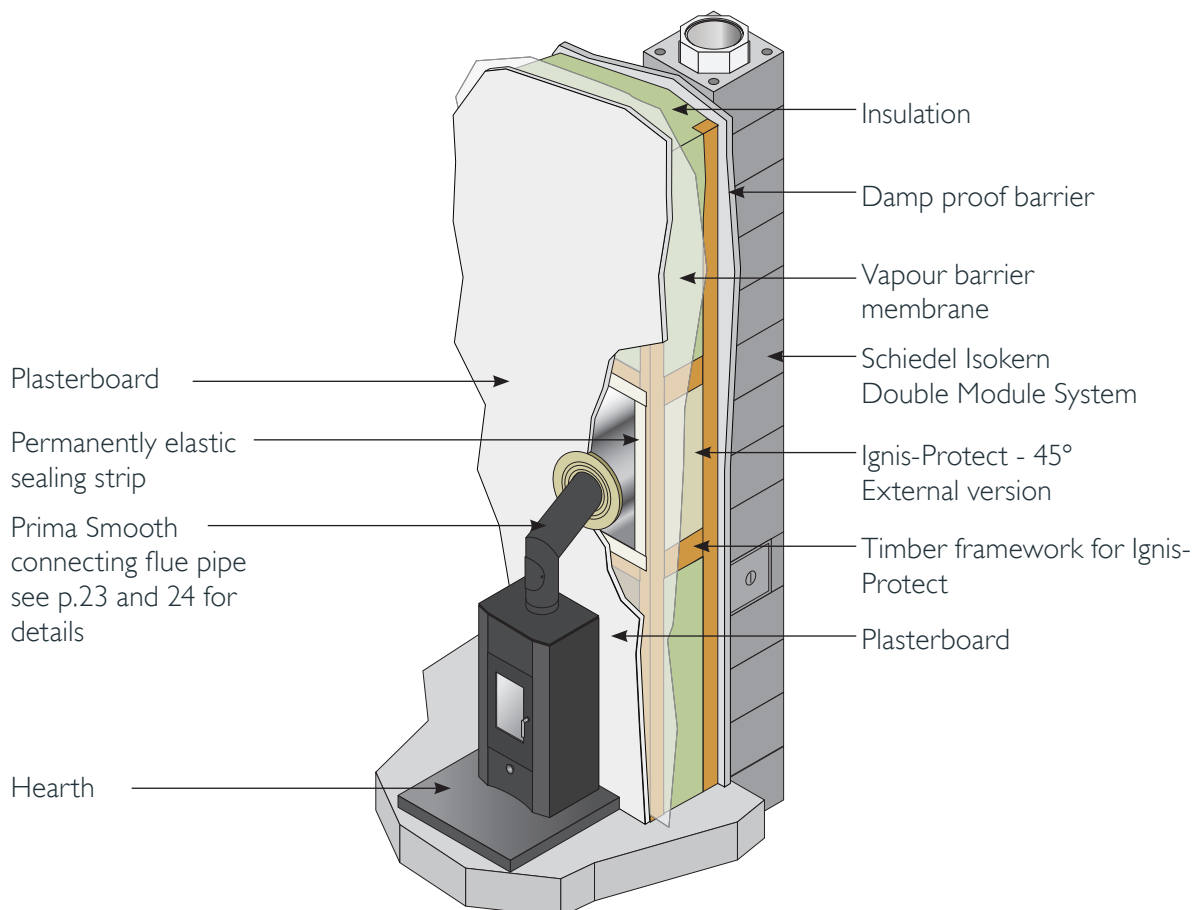



The Celsius system is a DEFRA exempt, modern fireplace insert, generating energy efficient warmth and comfort, as well as style.

The package is available in separate blocks, with all materials included for an installation in a new build, major renovation or a luxury home.

Scan the QR code to head over to YouTube to see an animated video showing how easy it is to put together



Easy to build - lasts a lifetime

- Simple and timeless design
- Block system can be supplied pre-built or as separate blocks.
- Can be placed with 0 mm distance to combustible material on the back and 300 mm to the sides
- Can be placed anywhere in the house as the air supply is integrated.
- Can be integrated into a non-combustible wall, saving space
- No high temperatures on surfaces of frame and surround
- Convection insert, which distributes heat in rooms
- Extremely energy efficient A+ rated
- Environmentally friendly combustion - clearSkies Level 5
- CE marked solution
- DEFRA exempt appliance for use in Smoke Control Areas

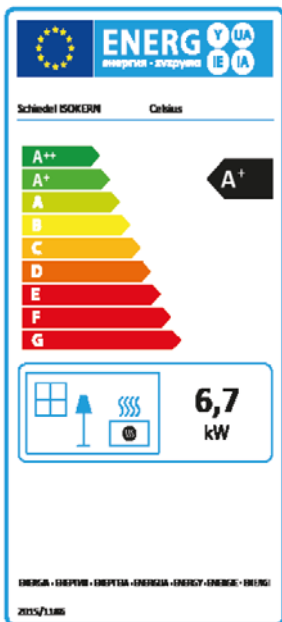

Technical	CELSIUS
Width	440 mm
Height	1500 mm
Depth	440 mm
Weight	240 kg

Efficiency	CELSIUS
Output	6.7 kW
Efficiency	A+
Energy Efficiency	83 %
Air Independent	✓

Air Independent	✓
DEFRA Exempt	✓
clearSkies Level 5	✓
Danish Technological Institute DS/EN13240/A2:2004 Norwegian Standard NS3058 and NS3059 (PM Measurement) European Standard EN16510-1:2018	



DEFRA EXEMPT
The Celsius is DEFRA Exempt so it can be installed and used in Smoke Control Areas in the United Kingdom, when operated in accordance with the instruction and installation manuals and when any conditions are met.



CLEARSKIES LEVEL 5
Celsius has achieved the highest level in clearSkies certification, which means that it exceeds the minimum performance level for Ecodesign Regulations.

Connecting Flue Pipe – Prima Smooth

Prima Smooth is a high quality 316L grade stainless steel single wall flue system available with two wall thickness options of 0.6mm and 1mm. Prima Smooth has been tested and approved for use as connecting flue pipe between an appliance and a Pumice System Chimney.

TRADITIONAL STANDARD KITS

Stove in Recess Basic Kit

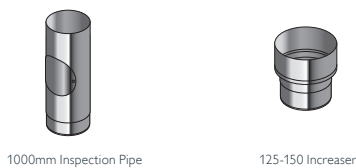

Through the Wall Kit 45°

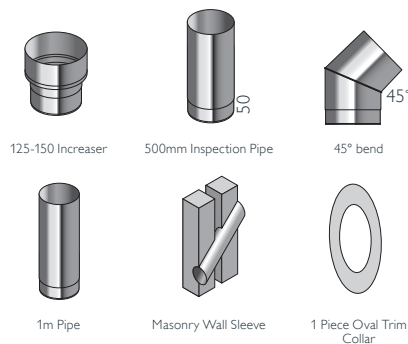

Through the Wall Kit 90°

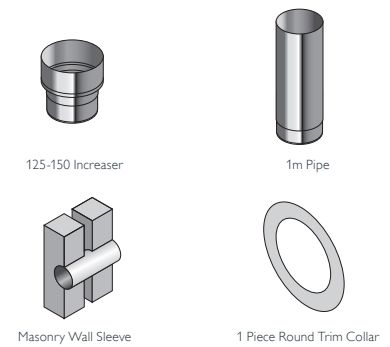

Stove in Recess Basic Kit	SAP code Ø150	SAP code Ø180
1000mm Inspection Pipe	114708	119962
125-150 Increaser	110211	126294

Through the Wall Kit 45°	Ø150	Ø180
Kit Contains	169143	169145
125-150 Increaser	x 1	x 1
500mm Inspection Pipe	x 1	x 1
45° bend	x 1	x 1
1m Pipe	x 1	x 1
Masonry Wall Sleeve	x 1	x 1
1 Piece Oval Trim Collar	x 1	x 1

Through the Wall Kit 90°	Ø150
Kit	169144
125-150 Increaser	x 1
1m Pipe	x 1
Masonry Wall Sleeve	x 1
1 Piece Round Trim Collar	x 1

Starting Components

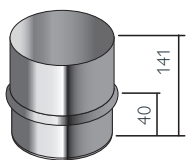

Appliance Connector				0.6mm PS013	1mm PS113		
Int Ømm Prima Smooth	125	125	150	150	180	200	
Appliance Spigot mm	126	128	148	153	178	198	
SAP Code Painted	0.6mm	125359	125363	126253	126257	119939	119937
	1mm	125360	125364	126254	126258	119931	119929
SAP Code Unpainted	0.6mm	125361	125365	126255	126259	119940	119938
	1mm	125366	125366	126256	126260	119932	119930

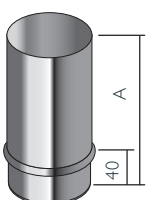

Swaged Starter Pipes				0.6mm PS013	1mm PS113
Int Ømm Prima Smooth		125	150	180	200
Appliance Spigot mm		123	148	178	198
Painted A 1000	1mm	133984	133987	133993	133996
Unpainted A 1000	1mm	133956	133959	133965	133968
Painted A 500	1mm	133985	133988	133994	133997
Unpainted A 500	1mm	133957	133960	133966	133969
Painted A 250	1mm	133986	133989	133995	133998
Unpainted A 250	1mm	133958	133961	133967	133970

Connecting Flue Pipe – Prima Smooth

Pipes

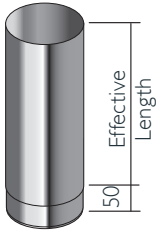

Standard Pipe Effective Length 950mm			0.6mm PS001	1mm PS101	
Int Ømm		125	150	180	200
SAP Code Painted	0.6mm	122583	114554	119860	119858
	1mm	122584	119954	119957	119955
SAP Code Unpainted	0.6mm	113272	114550	119861	119859
	1mm	115948	116338	119958	119956

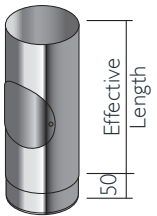

Inspection Pipe Effective Length 950mm			0.6mm PS011	1mm PS111	
Int Ømm		125	150	180	200
SAP Code Painted	0.6mm	114177	114707	119864	119862
	1mm	115979	116477	119961	119959
SAP Code Unpainted	0.6mm	114179	114709	119865	119863
	1mm	113482	114708	119962	119960

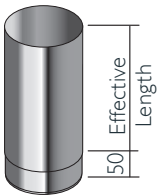

Standard Pipe Effective Length 450mm			0.6mm PS002	1mm PS102	
Int Ømm		125	150	180	200
SAP Code Painted	0.6mm	122585	111973	119868	119866
	1mm	125375	120601	119965	119963
SAP Code Unpainted	0.6mm	111487	111972	119869	119867
	1mm	112994	113393	119966	119964

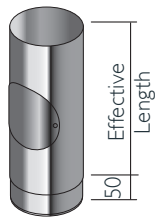

Inspection Pipe Effective Length 450mm			0.6mm PS012	1mm PS112	
Int Ømm		125	150	180	200
SAP Code Painted	0.6mm	112081	112155	119872	119870
	1mm	114182	114252	119969	119967
SAP Code Unpainted	0.6mm	112083	112150	119873	119871
	1mm	111608	112115	119970	119968

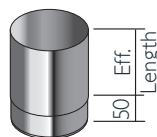

Standard Pipe Effective Length 200mm			0.6mm PS003	1mm PS103	
Int Ømm		125	150	180	200
SAP Code Painted	0.6mm	122586	110716	119880	119878
	1mm	125374	120602	119977	119975
SAP Code Unpainted	0.6mm	110485	110723	119881	119879
	1mm	111302	111543	119978	119976

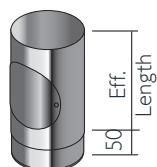

Inspection Pipe Effective Length 250mm			0.6mm PS004	1mm PS104	
Int Ømm		125	150	180	200
SAP Code Painted	0.6mm	122587	111169	119876	119874
	1mm	122588	119985	119973	119971
SAP Code Unpainted	0.6mm	110885	111165	119877	119875
	1mm	110850	110850	119974	119972

Connecting Flue Pipe – Prima Smooth

Bends / Additional Components

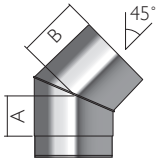

45° Bend		0.6mm PS015 1mm PS115			
Int Ømm		125	150	180	200
A mm		73	73	73	73
B mm		122	122	122	122
SAP Code Painted	0.6mm	121422	110717	119911	119909
	1mm	122589	120013	120007	120005
SAP Code Unpainted	0.6mm	110468	110720	119912	119910
	1mm	110515	110707	120008	120006

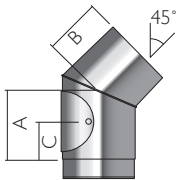

45° Inspection Bend		0.6mm PS044 1mm PS144			
Int Ømm		125	150	180	200
A mm		155	155	155	155
B mm		122	122	122	122
C mm		94	94	94	94
Inspection Hole Ø mm		100	130	130	130
SAP Code Painted	0.6mm	122594	111335	119915	119913
	1mm	121423	120004	120011	120009
SAP Code Unpainted	0.6mm	110875	111332	119916	119914
	1mm	110948	111324	120012	120010

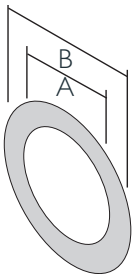

1 Piece Trim Collar 90° 0.6mm 9580P				
Int Ømm		150	180	200
A mm		154	184	204
B mm		300	330	350
Painted	0.6mm	126337	127039	127643
	0.6mm	164279	127038	127642

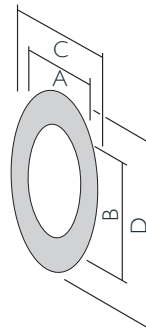

1 Piece Trim Collar 45° 0.6mm 9589P				
Int Ømm		150	180	200
A mm		154	184	204
B mm		215	259	287
C mm		300	330	350
D mm		412	454	483
Painted	0.6mm	147394	126613	127187
	0.6mm	125887	126612	127186

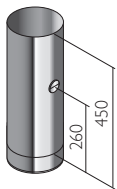

Test Point		0.6mm PS003 1mm PS103			
Int Ømm		125	150	180	200
SAP Code Painted	0.6mm	146361	146365	146369	146373
	1mm	146371	146375	146363	146367
SAP Code Unpainted	0.6mm	146360	146364	146368	146372
	1mm	146362	146366	146370	146374

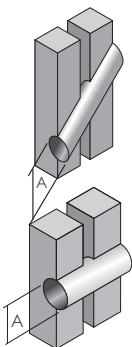

Wall Sleeve 45° (for masonry wall only) 94620						
A Masonry		200	230	250	288	306
SAP Codes Masonry		125894	126641	127205	128102	128587

Supplied as a 1m long mitred tube to be cut to length on site. For timber framed houses, see Ignis Protect on p.23

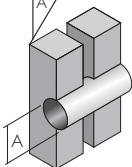

Wall Sleeve 90° (for masonry wall) 94980					
A Masonry		200	230	250	250
SAP Codes Masonry		147392	126642	127206	127206

For timber framed houses, see Ignis Protect on p.23

Useful Charts and Information

FLUE AREA AND LIP GLUE QUANTITY CHART



Int. Diameter of Liners & Flue Blocks (mm)	Ext. Diameter of Liner (mm)	Int. Area of Liner (cm ²)	Approx number of joints per bag of glue
150	200	177	16
175	235	240	14
200	250	314	12
225	285	397	11
250	310	491	10
300	360	707	9
350	416	962	7
400	470	1256	6
450	530	1590	5
500	590	1963	5
600	710	2826	4
DM36 Casing			6
DM44 Casing			5
DM54 Casing			4
DM36 Offset Blocks			5
DM44 Offset Blocks			3
DM54 Offset Blocks			

LIGHT EXPANDED CLAY AGGREGATE CALCULATION CHART



Int. Diameter of Liners & Flue Blocks (mm)	Ext. Diameter of Liner (mm)	Int. Size of Chimney (mm)	Bags per Linear metre
150	200	235 x 235	0.48
150	200	235 x 350	1.02
150	200	350 x 350	1.82
175	235	350 x 350	1.58
175	235	350 x 460	2.35
175	235	460 x 460	3.36
200	250	350 x 350	1.47
200	250	350 x 460	2.24
200	250	460 x 460	3.25
225	285	350 x 350	1.17
225	285	350 x 460	1.94
225	285	460 x 460	2.96
250	310	350 x 350	0.94
250	310	350 x 460	1.71
250	310	460 x 460	2.72
300	360	460 x 460	2.20
300	360	460 x 575	3.25
300	360	575 x 575	4.58
350	416	460 x 460	1.51
350	416	460 x 575	2.57
350	416	575 x 575	3.89
400	470	575 x 575	3.14

Useful Charts and Information

OFFSET DIMENSION CHART

Int. Diameter of Liners (mm)	Angle of Bend	Overall Combined Height	Offset Distance (mm)
150	15°	427	56
150	30°	456	122
150	45°	467	194
175	15°	435	57
175	30°	471	126
175	45°	489	202
200	15°	440	58
200	30°	481	129
200	45°	503	208
225	15°	449	59
225	30°	499	134
225	45°	528	219
250	15°	456	60
250	30°	511	137
250	45°	545	222
300	15°	469	63
300	30°	536	144
300	45°	581	240
350	15°	483	63
350	30°	564	151
350	45°	620	257

PAIR OF BENDS

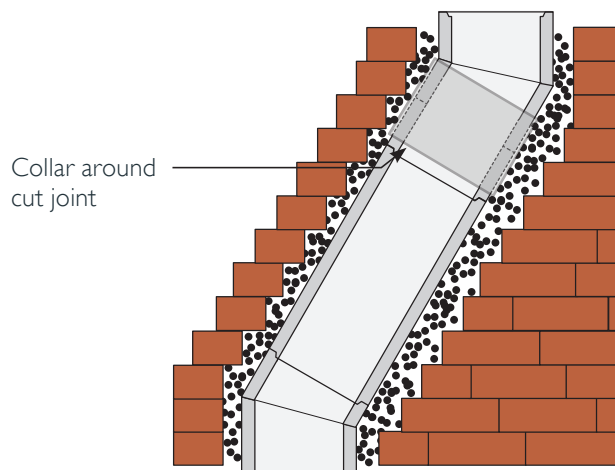
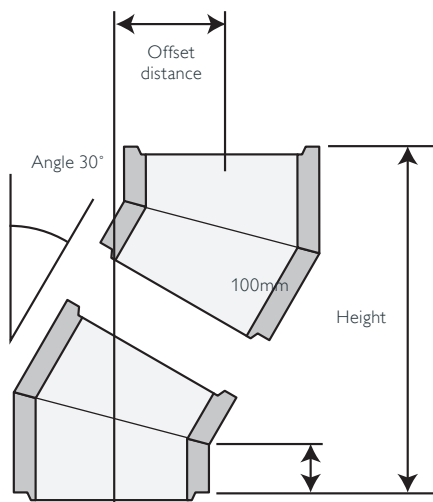

Useful Charts and Information

CHIMNEY HEIGHTS

On solid fuel and wood burning applications, the minimum recommended flue height is 4.5m from above the fire place opening or top of the appliance. For shorter flue heights a draft calculation would be required in line with the flue sizing requirements of EN13384-1.

The maximum freestanding stack height above the roof for a traditional coursed masonry chimney is 4.5 times the narrowest horizontal part of the chimney.

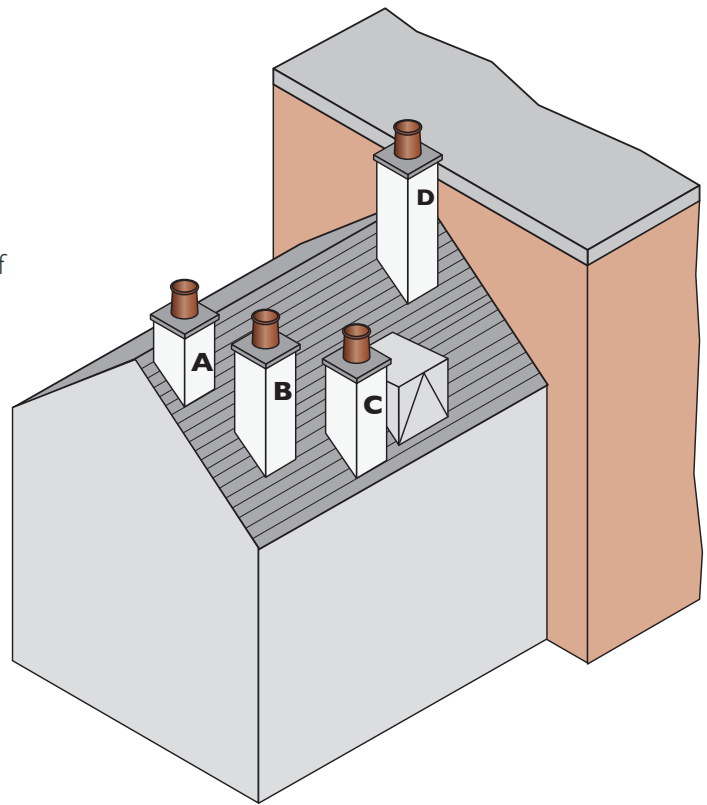

CHIMNEY HEIGHTS ABOVE ROOF

	Point where flue passes through weather surface (Notes 1,2)	Clearances to flue outlets
A	at or within 600mm of the ridge	at least 600mm above the ridge
B	elsewhere on a roof (whether pitched or flat)	at least 2300mm horizontally from the nearest point on the weather surface and: A) at least 1000mm above the highest point of intersection of the chimney and the weather surface: or B) at least as high as the ridge
C	below (on a pitched roof) or within 2300mm horizontally to an openable rooflight, dormer window or other opening (Note 3)	at least 1000mm above the top of the opening
D	within 2300mm of an adjoining or adjacent building, whether or not beyond the boundary (Note 3)	at least 600mm above the adjacent building

For clearances to easily ignitable roof coverings such as thatch refer to diagram 2.2 of Approved Document J 2010 Edition

NOTES

1. The weather surface is the building external surface, such as its roof, tiles or external walls.
2. A flat roof has a pitch less than 10°.
3. The clearances given for A or B as appropriate will also apply.

Useful Charts and Information

VENTILATION REQUIREMENTS

It is very important that sufficient air for combustion and ventilation is provided to the room containing the appliance, to enable correct and efficient working of the appliance and chimney system. Reference should be made to the appliance manufacturer's instructions and recommendations are also given in the Building Regulations Document J, see below:

CARBON MONOXIDE ALARMS

Where a new or replacement fixed solid fuel appliance is installed in a dwelling, a carbon monoxide alarm should be provided in the room where the appliance is located.

The carbon monoxide alarms should comply with BS EN 50291:2001.

The carbon monoxide alarm must be located in the same room as the appliance:

- a) On the ceiling at least 300mm from any wall or if it is located on a wall, as high up as possible (above any doors and windows), but not within 150mm of the ceiling and
- b) between 1m and 3m horizontally from the appliance.

N.B Provision of a carbon monoxide alarm should not be regarded as a substitute for correct installation and regular servicing.

VENTILATION REQUIREMENTS FOR SOLID FUEL

Type of Appliance	Type and amount of Ventilation (1)
Open appliance, such as an open fire with no throat, e.g. a fire under a canopy as in Diagram 23.	Permanently open air vent(s) with a total equivalent area of at least 50% of the cross sectional area of the flue.
Open appliance, such as an open fire with a throat, as in Diagrams 22 and 29.	Permanently open air vent(s) with a total equivalent area of at least 50% of the throat opening area. (2)
Other appliance, such as a stove, cooker or boiler, with a flue draught stabiliser.	Permanently open air vents as below: If design air permeability > 5.0m ³ /(h.m ²) then 300mm ² /kW for first 5kW of appliance rated output 850mm ² /kW for balance of appliance rated output If design air permeability ≤ 5.0m ³ /(h.m ²) then 850mm ² /kW of appliance rated output (4)
Other appliance, such as a stove, cooker or boiler, with no flue draught stabiliser.	Permanently open vents as below: If design air permeability > 5.0m ³ /(h.m ²) then 550mm ² /kW of appliance rated output above 5kW If design air permeability ≤ 5.0m ³ /(h.m ²) then 550mm ² /kW of appliance rated output (4)

Notes:

- Equivalent area is as measured according to the method in BS EN 13141-1:2004 or estimated according to paragraph 1.14. Divide the area given in mm² by 100 to find the corresponding area in cm².
- For simple open fires as depicted in Diagram 29, the requirement can be met with room ventilation areas as follows:

Nominal fire size (fireplace opening size)	500mm	450mm	400mm	350mm
Total equivalent area of permanently open air vents	20,500mm ²	18,500mm ²	16,500mm ²	14,500mm ²

- Example: an appliance with a flue draught stabiliser and a rated output of 7kW would require an equivalent area of (5 × 300) + (2 × 850) = 3200mm²
- It is unlikely that a dwelling constructed prior to 2008 will have an air permeability of less than 5.0m³/h.m² at 50Pa unless extensive measures have been taken to improve airtightness. See Appendix F.

MAGNUM COMBUSTION AIR REQUIREMENT

Size of Magnum Firechest	Free Air in cm ²	Free Air in mm ²
500	200	20.000
950	248	24.800
1100	338	33.800
1200	385	38.500

MAGNUM FIREBRICK, LIP GLUE & MORTAR QUANTITY

Size of Magnum Firechest	25mm thick Bricks	50mm thick Bricks	Lip Glue	Firebrick Mortar
500	Included	Included	2	Included
950	40	34	5	2
1100	40	44	6	2
1200	40	48	6	2

Useful Guides

THE SCHIEDEL INSTALLATION APP

This handy mobile guide can be used on mobile devices and touchscreen tablets.

It offers a number of very useful guides on all aspects of installing an appliance using Schiedel Chimney Systems, including:

- Quick and straightforward reference for installers.
- Video breakdowns of each stage of the installation process, from connection to the appliance through to termination.
- Highlighting the safety critical areas where the chimney penetrates the floors, ceilings, roof and walls.
- Incorporates frequently asked questions information at each stage of the installation process, in line with building regulations.
- An easy-to-use system for downloading full product information and installation instructions.
- Register your installation in the App.

Download the iPhone and iPad version in the App Store and Android version in the Google Play Store.

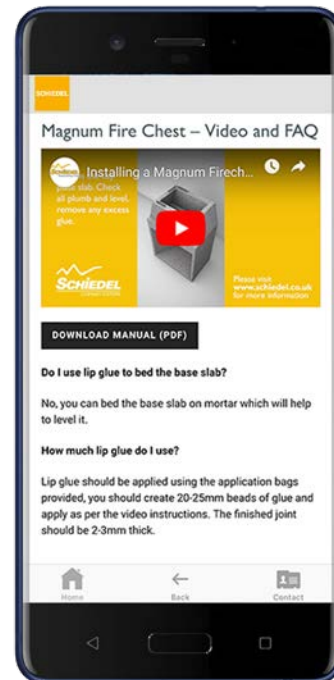

DOWNLOADS SPECIALIST CENTRE

We have a comprehensive range of CAD cells, typical installations using Isokern Pumice components and other diagrams, which are ideal resources for architects and builders when designing a chimney system for a new build or renovation

Visit our website and head over to the **SPECIALIST CENTRE** which can be found under the **SCHIEDEL WORLD** menu, or contact us and we will send a USB stick with all the relevant information and downloads on.

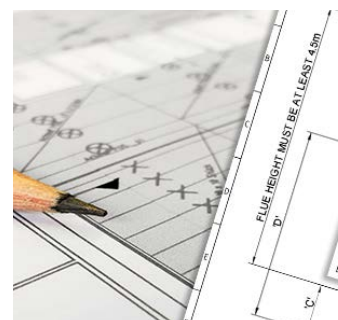

Schiedel Installer Rewards

Exciting news from Schiedel Chimney Systems for Stove and Chimney Installers! Whenever you register an installation with our easy to use, online registration portal, you will now accrue points based on the number of installations and installation type.

Once you have reached a minimum of 25 points, you can begin to redeem them for £25 Love2Shop vouchers.

So head on over to the portal at www.schiedelrewards.co.uk to register



Complementary Products and Services from Schiedel Chimney Systems



ICID PLUS
Twin Wall System Chimney for traditional stoves, pellet stoves, biomass appliances, mini/micro CHP and condensing boilers capable of withstanding positive pressure.

- 100-200 Internal diameter range



PRIMA SMOOTH
Single Wall Stainless Steel Connecting Flue Pipe for use on wood and multi-fuel applications.

- 316L Grade stainless steel
- Available in matt black or steel finish
- 125-200mm internal diameters

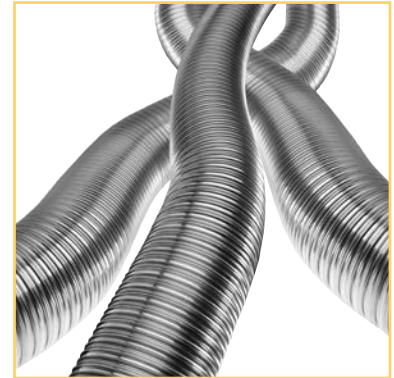

TECNOFLEX PLUS
For relining existing chimneys to take gas, oil, wood, multi-fuel appliances and open fires.

- Twin skin TecnoFlex Plus available in 316L or 904L options
- 80-300mm Diameter range



SIRIUS STOVE PACKAGE
Complete Ecodesign stove and concentric, air-tight chimney flue system for a bungalow, log cabin or house. Approved for installation and use in Smoke Control Areas



CERAMIC LINERS
This new generation of rebated ceramic chimney liners is available as standard in the following diameter range: 160mm, 180mm, 200mm.

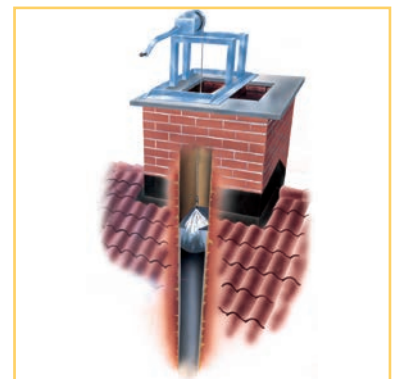

ISOKOAT FLUE SEALING SYSTEM
The Schiedel Isokoat system is an efficient and cost effective method of re-sealing a defective chimney shaft.



Schiedel Chimney Systems Ltd.
Unit 8 & 9, Block A, Holton Road
Holton Heath Industrial Estate
Poole, Dorset BH16 6LG
Tel. +44 (0)1202 861650

sales.uk@schiedel.com
www.schiedel.com/uk

SCHIEDEL INSTALLER REWARDS

Exciting news from Schiedel Chimney Systems! Whenever you register an installation with our easy to use, online registration portal, you will now accrue points based on the number of installations and installation type to redeem for Love2Shop vouchers!

Follow us on Social Media @SchiedelUK

A standard INDUSTRIES COMPANY