

SFL[®]

FLUE & CHIMNEY

Quality stainless steel twin wall flue system designed and built in Britain.
The NOVA range from SFL.

NOVA

Stainless steel twin wall chimney system
multi-functional applications serving a variety of fuels



NOVA

Stainless Steel Twin Wall System



British Built
Flue System



Twist-Lock®
Jointing



Black Colour
Option

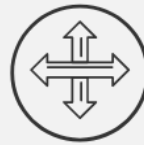

50mm To
Combustibles



Multi-Fuel
Appliances



T600
Rating

Performance. Quality. Efficiency.

Nova's Stainless Steel Twin Wall
System

The NOVA® family of products has been specifically designed to meet the requirements for multi-functional applications serving a variety of fuels. Whether serving a traditional negative draught appliance or a modern high efficiency condensing appliance, the NOVA® product offers the ideal solution. With a wide range of components together with a multi-barb twist-lock jointing system, NOVA® offers the ultimate in ease of installation, quality and functionality. NOVA® is a CE approved product and has been tested to the requirements of BS EN 1856-1, see Table 1 - Chimney designation.

NOVA

Description

NOVA® is a prefabricated, factory made twin-wall insulated stainless steel system chimney. The fully welded construction combined with a high performance / high density insulating medium, provides the optimum level of performance required for today's modern high efficiency combustion equipment, as well as being suitable for the more traditional oil, gas and solid fuel fired appliance. The construction provides a high thermal resistance which ensures rapid stabilisation of the flue gas temperature and draught, whilst maintaining a relatively low temperature on the external surface of the chimney. NOVA® is designed for internal and external applications and is suitable for negative pressure applications. When used with a seal and where the flue gas temperature does not exceed 200°C, the NOVA® product is suitable for wet and positive pressure applications up to 200Pa (P1).

NOVA® utilises a multi-barb quick lock jointing system to secure each joint. The number of barbs depends on the product diameter, and in each case the components are secured by locating the barbs with a twist of each section. A locking band must then be used at each joint. The joint design facilitates a maximum unsupported height above the last support of up to 3.0 metres (2.0 metres for 100ID), subject to the design considerations detailed within the Installation Instructions and on page 30 of this brochure.

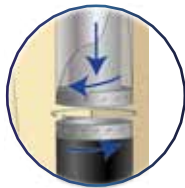

TWIST-LOCK JOINTING SYSTEM

NOVA® is manufactured from a high grade 316L (1.4404 : X2CrNiMo 17-12-2) stainless steel liner and a 304 (1.4301 : X5CrNiMo 18-10-2) outer case. The product utilises a high performance mineral wool which is auger filled into a 25mm annulus between the inner and outer, offering rapid stabilisation of draught and excellent thermal performance. The unique joint design allows the inner liner to freely expand and contract throughout the system as the flue gas temperature varies, alleviating the need for additional expansion component

Application

The NOVA® product is available in 8 internal diameters ranging from 100mm to 355mm and is suitable for oil, gas, and solid fuel applications operating under negative draught / dry conditions or where the maximum positive pressure will not exceed 40Pa as designated by N1, at a maximum flue gas temperature of 450°C.

Where used for solid fuel and oil applications where the flue gas temperature is greater than 250°C, the ventilated support components must be used as detailed on page 17.

For T600 temperature applications, NOVA® can only be applied where the chimney passes through non-combustible floors and where the chimney is enclosed throughout its length within a ventilated non-combustible enclosure or shaft. For more information, please contact SFL Technical Dept.

For condensing (WET) / positive pressure applications, where the flue gas temperature will not exceed 200°C at a maximum positive pressure of 200Pa (P1), an optional seal can be fitted to the NOVA® product as detailed on page 24.

For condensing applications it is important that any sloping runs are angled not less than 3° where head room is an issue or preferably 5° from the horizontal. Drainage components should also be incorporated into the system to allow condensate removal to a suitable drain or gully. Tees and elbows are provided within the NOVA® range to facilitate a 3° or 5° incline from the horizontal.

Table 1 - Chimney designation to BS EN 1856-1

NOVA product designations to BS EN 1856-1									
0086-CPD-496040	NOVA SM	BS EN 1856-1	T600*	N1	D	V2	L50050	G(50)	
0086-CPD-496040	NOVA SM	BS EN 1856-1	T450	N1	D	V2	L50050	G(50)	
0086-CPD-496040	NOVA SM	BS EN 1856-1	T200	P1	W	V2	L50050	O(50)	

Standard number	↑	↑	↑	↑	↑	↑	↑	↑	↑
Temperature class		↑	↑	↑	↑	↑	↑	↑	↑
Pressure class			↑	↑	↑	↑	↑	↑	↑
Condense resistance D=dry W=wet				↑	↑	↑	↑	↑	↑
Corrosion class					↑	↑	↑	↑	↑
Material specification Liner grade 316L Liner thickness: 0.5mm						↑	↑	↑	↑
Sootfire resistance G=yes O=no								↑	↑

Note: P1 rating requires seals fitted to the NOVA product

* T600 ONLY applies where the chimney passes through non-combustible floors and where the chimney is enclosed within a ventilated non-combustible enclosure / shaft.

Typical Domestic Installation

Nova

Design & Quote in Seconds

Create unique quotes for stove installations with the SFL UK App! Available for iPhone/iPad & Android or use on your PC internet by visiting app.sflchimneys.com

SFL UK

is free to download and generates list-price quotes on the spot. Using your unique quote reference, your SFL supplier can then provide a full bill of materials and a price-breakdown.

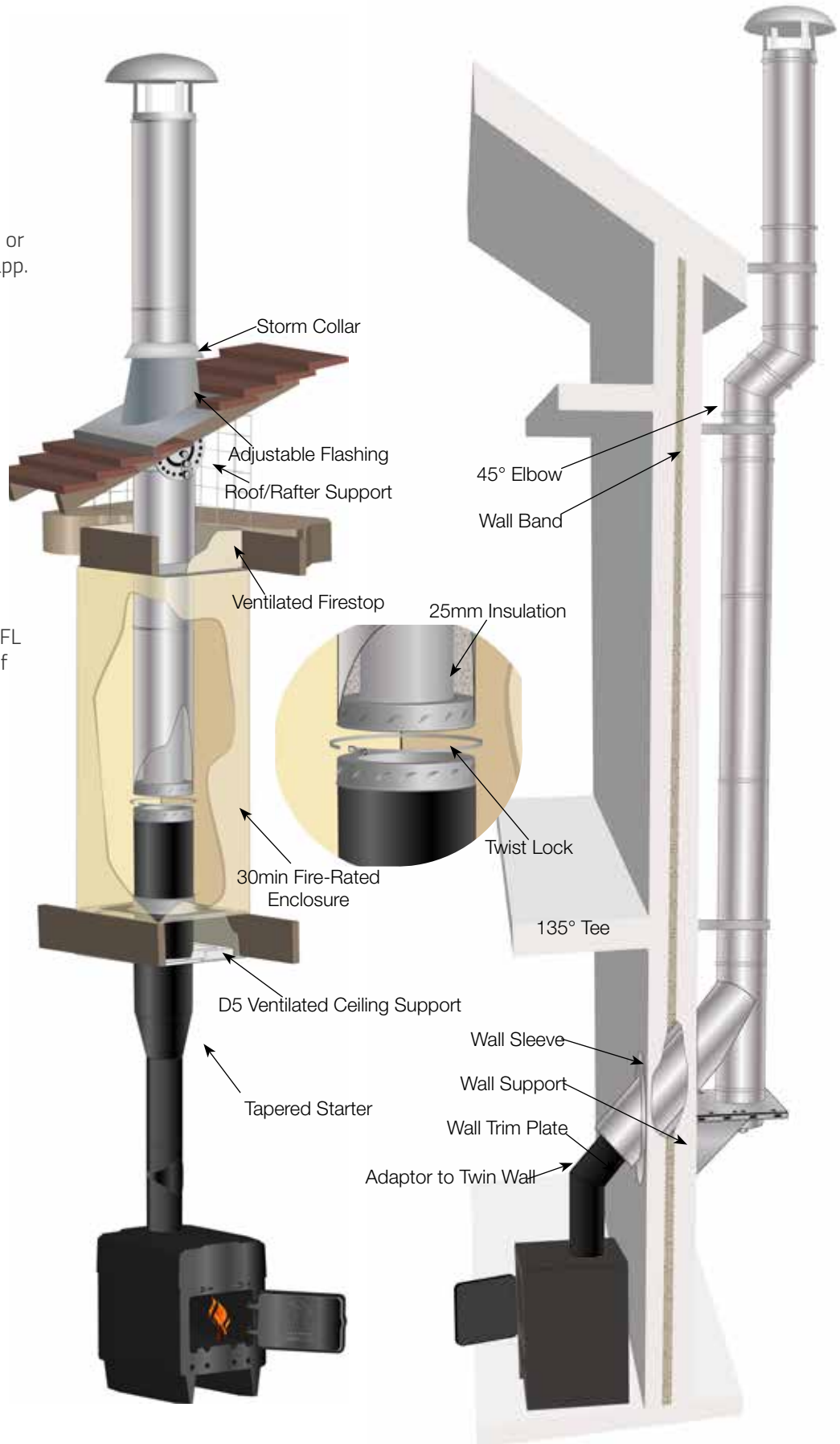

The ideal companion to Biomass heating appliances

Design & Quote in Seconds

Heralded as one of the most cost-effective, renewable and carbon-lean heat sources, wood, woodchip and wood pellet boilers are becoming increasingly popular throughout the UK & Europe.

NOVA® chimney system has been designed with the latest biomass plant in mind. From small household systems to full-scale public buildings, NOVA® is supported by a growing range of bespoke components for use with HETAS approved solid wood-based fuels.



To order NOVA® in satin black factory-finish, add a "B" to the end of the part number. e.g. for 150ID starter length, use part number 4570406NB

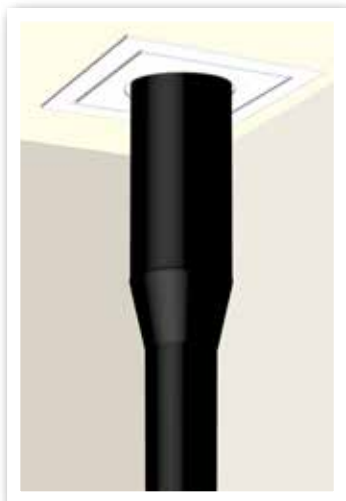

Lengths

Nova

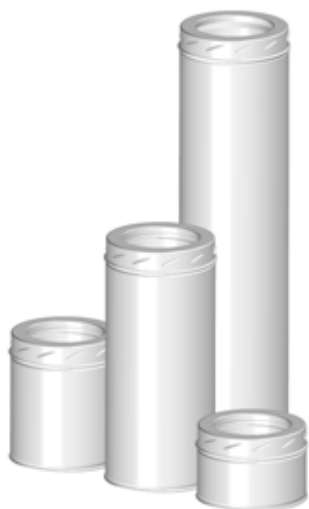

Straight Length

Available in nominal installed lengths of 1500mm, 1000mm, 500mm, 250mm & 120mm.

Ø	Installed Length			
	120mm Code	250mm Code	500mm Code	1000mm Code
100mm	4575304N	4571904N	4575104N	4575004N
130mm	4575305N	4571905N	4575105N	4575005N
150mm	4575306N	4571906N	4575106N	4575006N
180mm	4575307N	4571907N	4575107N	4575007N
200mm	4575308N	4571908N	4575108N	4575008N
250mm	4575310N	4571910N	4575110N	4575010N
304mm	4575312N	4571912N	4575112N	4575012N
355mm	4575314N	4571914N	4575114N	4575014N

1500mm	
150mm	4579906N



Adjustable Length

The adjustable length offers a degree of flexibility when standard length dimensions are not suitable. All adjustable lengths are supplied with separate insulating material for insertion into the annulus once the installed length has been determined.

As the insulation density is installed on site and not controlled by SFL, we would recommend that this component is located at least 300mm from any combustible material.

Type Ø	Short (210mm - 320mm) Code	Long (310mm - 500mm) Code	Seal
100mm	4576604N	4574604N	4006310
130mm	4576605N	4574605N	4006313
150mm	4576606N	4574606N	4006315
180mm	4576607N	4574607N	4006318
200mm	4576608N	4574608N	4006320
250mm	4576610N	4574610N	4006325

	Short (255mm - 410mm)	Long (330mm - 550mm)	Seal
304mm	4576612N	4574612N	4006530
355mm	4576614N	4574614N	4006535

Where Adjustable Lengths are required for positive pressure and condensate resistance, two seals are required per component. See page 29 for installation details.

Starter Length

Designed to offer an aesthetic transition from the appliance outlet or connecting flue pipe to the NOVA chimney system.

Ø	A (mm) O.D	Code
130mm	125mm	4570405N
150mm	150mm	4570406N
180mm	175mm	4570407N
200mm	200mm	4570408N

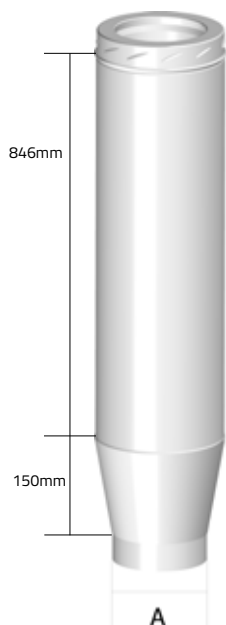



Adjustable Slip Length

An alternative to conventional adjustable lengths, this component consists of a length which will fit inside an existing chimney length and a cover jacket to be insulated by the installer with the insulation provided.

A distance of 300mm to combustible materials should be observed when installing this component.

N.B. This component does not form a complete length of twin-wall chimney (as do our regular adjustable lengths) and requires a standard straight length of the same diameter. See adjustment range data on P.28.

Ø	Code
100mm	4570004N
130mm	4570005N
150mm	4570006N
180mm	4570007N
200mm	4570008N
250mm	4570010N

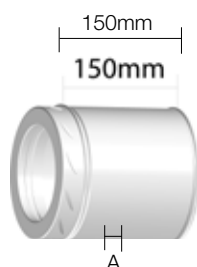

Duct Drain Length

Used in an inclined position to trap condensate and permit drainage. It is fitted with a standard stainless steel BSP thread connection and incorporates an internal back flow dam.

Ø	Dim A	Code
100mm	1" BSP	4576804N
130mm	1" BSP	4576805N
150mm	1" BSP	4576806N
180mm	1" BSP	4576807N
200mm	1" BSP	4576808N
250mm	1" BSP	4576810N
304mm	1" BSP	4576812N
355mm	1" BSP	4576814N

Probe Length

Supplied with a M16 threaded washer and bolt to facilitate a commissioning sampling probe. Cover jacket supplied to cover sampling point when not in use.

Ø	Code
100mm	4576704N
130mm	4576705N
150mm	4576706N
180mm	4576707N
200mm	4576708N
250mm	4576710N
304mm	4576712N
355mm	4576714N

Inspection Length – (N1/D)

Use to provide access for inspection or cleaning via an insulated lockable door. This component is only suitable for negative pressure/dry non-condensing applications. For positive pressure or wet condensing applications use the P1/W inspection length.

Ø	Code
100mm	N/A
130mm	4576205N
150mm	4576206N
180mm	4576207N
200mm	4576208N
250mm	4576210N
304mm	4576212N
355mm	4576214N

Inspection Length – (P1/W)

Use to provide access for inspection and cleaning. To be used for positive pressure and wet systems where the flue gases are likely to condensate within the chimney system. Suitable for flue gas temperatures up to 200°C at 200Pa.

Ø	Dims (mm)		Code
	A	B	
100mm	206	70	4576304N
130mm	206	80	4576305N
150mm	215	100	4576306N
180mm	215	100	4576307N
200mm	215	100	4576308N
250mm	215	100	4576310N

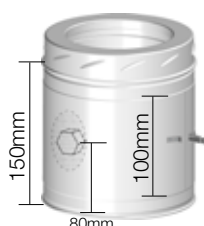

Damper Length (P1/W)

Use for balancing multi-inlet systems and to add resistance. Also suitable for wet systems.

Ø	Code
100mm	4574004N
130mm	4574005N
150mm	4574006N
180mm	4574007N
200mm	4574008N
250mm	4574010N
304mm	4574012N
355mm	4574014N



Elbows

Nova



2 Segment Elbows (15°, 30°, 40°, 45°)

Provides a change of direction, measured from the vertical by the specified angle. See technical data on page 27 for dimensions. Elbows are now supplied with an unbarbed female coupler and screw-toggle type locking band.

Angle	15° Code	30° Code	40° Code	45° Code
100mm	4575404N	4575504N	4575604N	4575704N
130mm	4575405N	4575505N	4575605N	4575705N
150mm	4575406N	4575506N	4575606N	4575706N
180mm	4575407N	4575507N	4575607N	4575707N
200mm	4575408N	4575508N	4575608N	4575708N
250mm	4575410N	4575510N	4575610N	4575710N
304mm	4575412N	4575512N	4575612N	4575712N
355mm	4575414N	4575514N	4575614N	4575714N

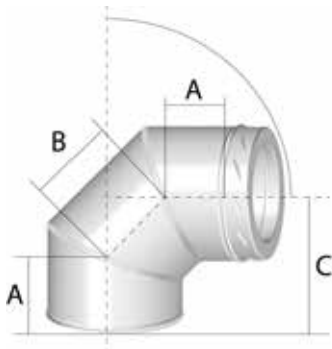

Three-segment 90°, 85° & 87° Elbows

Provides a change of direction measured from the vertical. Use 85° and 87° for condensing applications where a 5° or 3° incline (respectively) to the horizontal is required for condensate drainage.

Angle	Dimension (mm)			85° Code	Dimension (mm)			87° Code
	φ	A	B		C	A	B	
100mm	91	126	192	4575804N	91	126	185	4574904N
130mm	98	136	207	4575805N	98	136	200	4574905N
150mm	102	144	217	4575806N	102	144	210	4574906N
180mm	108	156	233	4575807N	108	156	226	4574907N
200mm	112	165	244	4575808N	112	165	236	4574908N
250mm	123	185	270	4575810N	123	185	262	4574910N
304mm	132	217	297	4575812N	132	217	291	4574912N
355mm	140	235	318	4575814N	140	235	312	4574914N

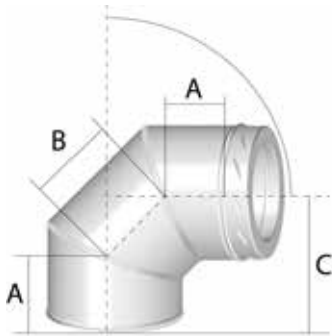

90° Elbow

Angle	Dimension (mm)			90° Code	Inspection Elbow				90° Code
	φ	A	B		C	A	B	C	
100mm	91	126	180	4575904N	91	272	283	180	4576104N
130mm	98	136	193	4575905N	98	272	290	180	4576105N
150mm	102	144	204	4575906N	102	282	301	200	4576106N
180mm	108	156	219	4575907N	108	282	307	200	4576107N
200mm	112	165	229	4575908N	112	282	311	200	4576108N
250mm	123	185	254	4575910N	123	282	322	200	4576110N
304mm	132	217	285	4575912N	133	282	332	200	4576112N
355mm	140	235	306	4575914N	143	282	342	200	4576114N

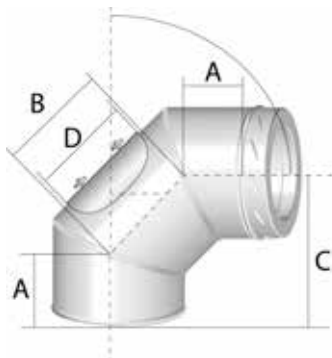

Inspection Elbow



Increasers

Nova

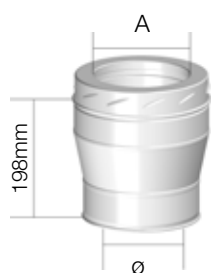

Increaser

Facilitates an increase in diameter by one step. Constructed with a smooth conical design and welded seams to prevent the build up of condensates

ø	Dim A (mm)	Code
100mm	130	4573604N
130mm	150	4573605N
150mm	180	4573606N
180mm	200	4573706N
200mm	250	4573608N

Eccentric Increaser

Designed specifically for condensing applications to provide an increase in diameter without pooling of condensation in horizontal or inclined runs.

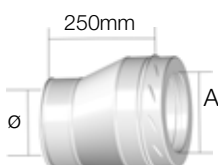

ø	A	Code
150mm	200mm	4570606N
180mm	250mm	4570607N
200mm	250mm	4570608N
200mm	304mm	4570708N
250mm	304mm	4570610N
250mm	355mm	4570710N

Tee Components

Locking Plug

Used to close off the branch or base of a tee or for use as an access/inspection component.

ø	Dims (mm)		Code
	A	B	
100mm	206	70	4576304N
130mm	206	80	4576305N
150mm	215	100	4576306N
180mm	215	100	4576307N
200mm	215	100	4576308N
250mm	215	100	4576310N
304mm	215	100	4576312N
355mm	215	100	4576314N

Specification	Diameter (mm)	
	150/180	200/250
Classification to DIN 4796	4	4
Adjustment Range (Pa)	10-33	4-35
Minimum Opening Pressure (mbar)	6	6
Maximum Flue Gas Temperature (°C)	400	400

Tee Components

Nova

Condensate Collector

Used at the bottom of a vertical chimney to facilitate the drainage of condensate from the system. Fitted with a stainless steel BSP external thread drain connection.

ø	BSP	A	Code
100mm	1"	63	4576904N
130mm	1"	63	4576905N
150mm	1"	63	4576906N
180mm	1"	63	4576907N
200mm	1"	63	4576908N
250mm	1"	63	4576910N
304mm	1"	63	4576912N
355mm	1"	63	4576914N

Draught Regulator

Dual action draught regulator suitable for gas, oil and solid fuel applications. Designed to be used with SFL chimney systems where excessive draught is likely to create combustion problems. When used with the NOVA chimney system, the regulator should be applied with the 45785XXN appliance adaptor (in turn located onto the 90° tee branch)

ø	Code
100mm	3192004
130mm	3192005
150mm	3192006
180mm	3192007
200mm	3192008
250mm	3192010
304mm	3192012
355mm	3192014

Draught Regulator c/w Pressure Relief

Ideal for use on biomass pellet appliances but also suitable for gas and oil fired appliances where the flue gas temperature will not exceed 400°C. The component also includes an explosion/pressure relief mechanism as required by many biomass appliance manufacturers. Supplied c/w Male Adaptor.

Note: This component is supplied with an un-barbed male coupler to allow the Draught Regulator to be positioned plumb vertical at any angle of flue-run.

ø	Code
150mm	4574206N
180mm	4574207N
200mm	4574208N
250mm	4574210N

Tees

Nova

90° Equal Tee

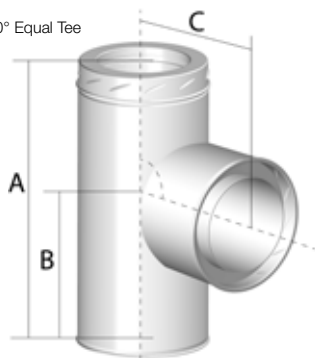

90° Equal Tee

Used as the entry to a vertical chimney, or for horizontal header configurations.

90° & 95° Reducing Tee

A wide variety of reducing tee combinations are available. Listed here are the most common single-step reductions (i.e. 150mm body, 130mm branch). For a full list of standard reducing tees, please visit www.sflchimneys.com.

Angle	Dimension (mm)			Reducing Tees			
Flue ϕ	A	B	C	90° Code	Branch ϕ	90° Code	95° Code
100mm	300	180	140	4573004N	-	-	-
130mm	330	195	155	4573005N	100mm	4559001	4559501
150mm	350	205	165	4573006N	130mm	4559003	4559503
180mm	380	220	180	4573007N	150mm	4559011	4559511
200mm	400	230	190	4573008N	180mm	4559021	4559521
250mm	450	255	215	4573010N	200mm	4559028	4559528
304mm	500	265	240	4573012N	250mm	4559034	4559534
355mm	550	305	265	4573014N	300mm	4559041	4559541

90° Reducing Tee



95° Reducing Tee

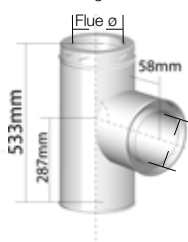

93° & 95° Equal Tee

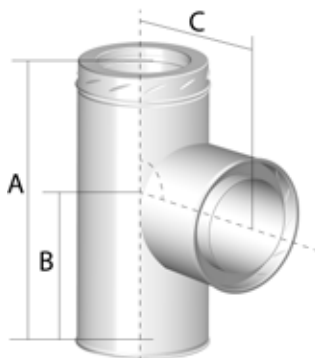

93° & 95° Equal Tee

Used at the base of a vertical chimney, or for horizontal header configurations. Allows for a 3° or 5° (respectively) incline on wet systems to allow for condensate drainage.

Angle	93°				95°			
	Dimension (mm)			Code	Dimension (mm)			Code
ϕ	A	B	C		A	B	C	
100mm	300	180	140	4573304N	300	180	140	4576404N
130mm	330	195	155	4573305N	330	195	155	4576405N
150mm	350	205	165	4573306N	350	205	165	4576406N
180mm	380	220	180	4573307N	380	220	180	4576407N
200mm	400	230	190	4573308N	400	230	190	4576408N
250mm	450	255	215	4573310N	450	255	215	4576410N
304mm	500	286	240	4573312N	500	286	240	4576412N
355mm	550	305	270	4573314N	550	305	270	4576414N

135° Tee

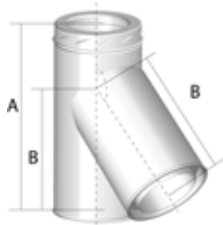

135° Tee & Elbow

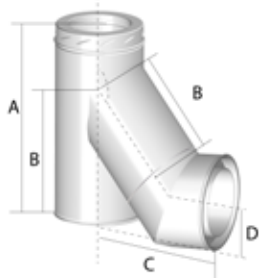

135° Tee

Used at the base of a vertical chimney, or to allow a smooth transition from the horizontal to vertical plain when used with a 45° elbow. The coupler on the branch is unbarbed to allow unlimited rotational adjustment and provided with an adjustable screw-toggle locking band.

ϕ	Dimension (mm)						Code
	With 40° Elbow		With 45° Elbow				
	A	B	C	D	C	D	
100mm	495	325	385	23	385	31	4576504N
130mm	495	340	407	22	407	30	4576505N
150mm	495	375	439	29	439	38	4576506N
180mm	745	420	481	37	481	47	4576507N
200mm	745	450	509	43	509	53	4576508N
250mm	745	520	577	55	577	65	4576510N
304mm	745	585	625	73	625	84	4576512N
355mm	995	650	688	84	688	96	4576514N

Appliance Adaptor

Used to connect the appliance outlet to the NOVA® chimney system. This adaptor is also used for connection of the draught regulator to the branch of a 90° tee. Also used to connect NOVA® to Sigma single wall connecting flue pipe.

∅	Dim A (mm)	O.D.	Code
100mm	63	98	4578504N
130mm	63	128	4578505N
150mm	63	148	4578506N
180mm	63	178	4578507N
200mm	63	198	4578508N
250mm	63	248	4578510N
304mm	63	298	4578512N
355mm	63	348	4578514N

Appliance Adaptor (Imperial)

Used for connection to appliances with imperial or equivalent spigots.

∅	A	B	Code
130mm	63	125mm	4578405N
180mm	63	175mm	4578407N

Appliance Increaser Adaptor

Used to increase the appliance outlet size by one diameter.

∅	O.D. (A)	Code
100mm	80mm	4579404N
150mm	123mm	4579505N
150mm	130mm	4579405N

Supra to NOVA® Adaptor

Used to connect from the SUPRA chimney system or for use as an appliance adaptor.

∅	Code
100mm	4579604N
130mm	4579605N
150mm	4579606N
180mm	4579607N
200mm	4579608N
250mm	4579610N
304mm	4579612N
355mm	4579614N

NOVA® to Supra Adaptor

Designed to facilitate connection from the NOVA® to Supra chimney system.

∅	Code
100mm	4579704N
130mm	4579705N
150mm	4579706N
180mm	4579707N
200mm	4579708N
250mm	4579710N
304mm	4579712N
355mm	4579714N

NOVA® to Flex Adaptor

Used to connect the NOVA® product to a flexible flue liner. Supplied with clamp band for ease of installation.

∅	A	B	Code
100mm	113	96	4573404N
130mm	138	121	4573405N
150mm	163	146	4573406N
180mm	190	171	4573407N
200mm	213	196	4573408N
250mm	263	246	4573410N
304mm	313	296	4573412N
355mm	363	346	4573414N

Flex to NOVA® Adaptor

Used to connect a flexible flue liner to NOVA®, e.g. where a masonry chimney has been capped within a roof void. Supplied with clamp band for ease of installation.

∅	A	B	Code
100mm	113	96	4573204N
130mm	138	121	4573205N
150mm	163	146	4573206N
180mm	190	171	4573207N
200mm	213	196	4573208N
250mm	263	246	4573210N
304mm	313	296	4573212N
355mm	363	346	4573214N

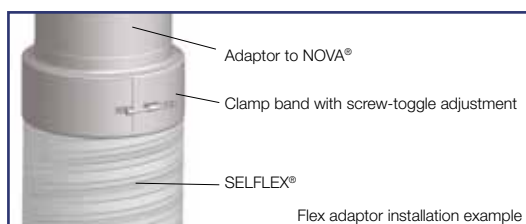

Adaptors

Specials for NOVA®

Adaptors

Fax to 01271 334303

Although we manufacture an extensive range of components, SFL understands that there are times when a standard component will simply not work for the intended installation. Being a UK manufacturer, we are ideally placed to manufacture bespoke components in a timely and competitive manner. Please photocopy and complete the required dimensions for the required special component and fax / scan and email your requirements to SFL Customer Services Dept, who will be happy to offer a quotation and lead time.

For Standard 90° & 95° Reducing Tees

Standard & Reducing Tees

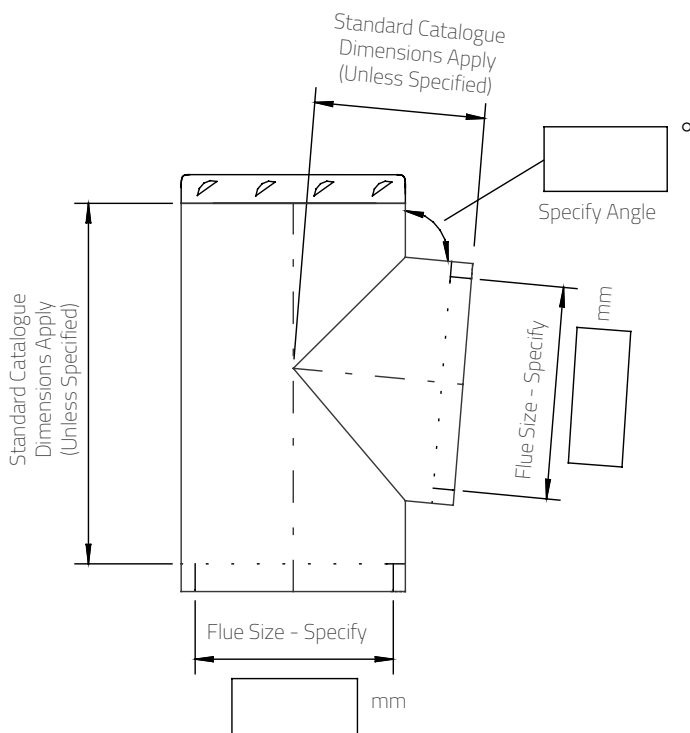

Appliance Adaptors

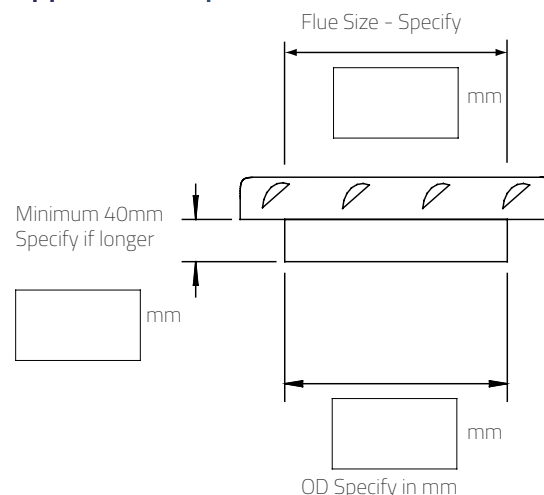

Elbows

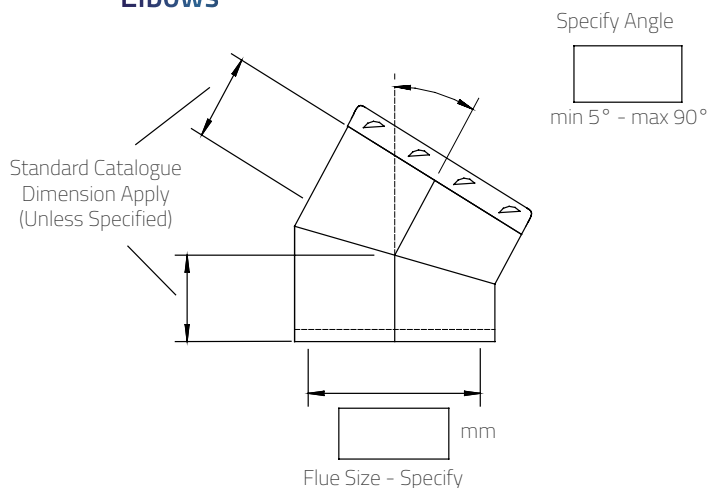

Customer Name
Customer Address
Telephone Number
Email Address
Comments

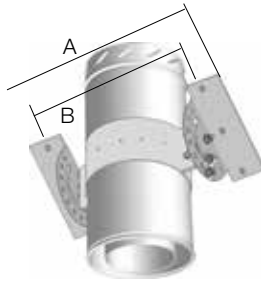

Roof / Rafter Support

Provided with adjustable and locking gimbal plates to permit a chimney to be supported on roof joists, trussed rafters etc. Maximum suspended chimney length supported is 6.0 metres and maximum total length supported is 9.0 metres.

∅	A	B	Code
100mm	418	310	7072610
130mm	448	340	7072613
150mm	468	360	7072615
180mm	498	390	7072618
200mm	518	410	7072620
250mm	568	460	7072625
304mm	618	510	7072630
355mm	668	560	7072635



Single Wall to NOVA® Anchor Plate

Designed to be used when connecting NOVA® to a lintel or pre-cast chamber. A short section of liner projects a nominal 32mm through the bottom of the plate. Installed length "H" is 40mm while "E" is 27mm and there are 8 x 11mm fixing holes at the centres shown in the table below. Manufactured in stainless steel. Maximum Load: 13m

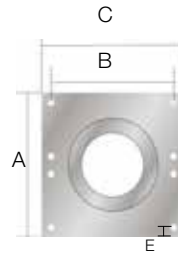

∅	A	B	C	Code
100mm	281	196	252	4577504N
130mm	311	226	282	4577505N
150mm	331	246	302	4577506N
180mm	360	275	331	4577507N
200mm	384	299	355	4577508N
250mm	432	345	403	4577510N
304mm	482	395	453	4577512N
355mm	533	446	504	4577514N



Universal Split Band

Offers lateral support to the chimney system. The split band has adjustable brackets to allow the support of inclined runs. Design for use with M10 Drop Rod.

∅	Code
100mm	3123150
130mm	3123180
150mm	3123200
180mm	3123230
200mm	3123250
250mm	3123300
304mm	3123350
355mm	3123400

For loading details and maximum distance between supports, please see page 28

Support length (Strut/Guy Attachment)

A 117mm installed length which incorporates a plate located 33mm from the bottom edge and features slotted holes for rotational adjustment. This component also doubles as a strut / guy attachment length offering anchoring points to which guys, or preferably rigid stays can be secured using M8 nuts and bolts. Manufactured from stainless steel.



∅	Code
100mm	4578804N
130mm	4578805N
150mm	4578806N
180mm	4578807N
200mm	4578808N
250mm	4578810N
304mm	4578812N
355mm	4578814N



Support Components

Nova

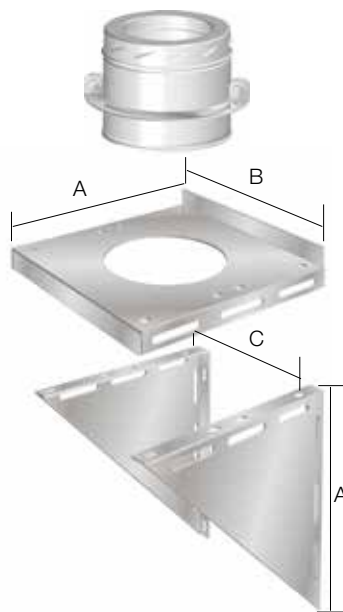

Wall Support Bracket

Used to take the vertical load of the chimney when supported from a wall. The support bracket is fully adjustable allowing varying clearances from the wall (50mm as standard). Requires M10 wall fixings.

∅	A	B	C	Stainless Code	Galvanised Code
100mm	252	281	235	4572304	4572204
130mm	282	311	265	4572305	4572205
150mm	302	331	285	4572306	4572206
180mm	331	360	314	4572307	4572207
200mm	355	384	338	4572308	4572208
250mm	403	432	384	4572310	4572210
304mm	453	482	434	4572312	4572212
355mm	504	533	485	4572314	4572214

For loading details and maximum distance between supports, please see page 28

Universal Support Plate

A support plate designed for use with bespoke bracketry such as Uni-Strut/Niessing or site fabricated. Supplied complete with a Support Length. Fixing hole size 11mm to suit M10 fixings.

∅	A	B	C	Max Load	Stainless Code	Galvanised Code
100mm	281	196	252	13m	4571704N	4571404N
130mm	311	226	282	13m	4571705N	4571405N
150mm	331	246	302	13m	4571706N	4571406N
180mm	360	275	331	13m	4571707N	4571407N
200mm	384	299	355	13m	4571708N	4571408N
250mm	432	345	403	13m	4571710N	4571410N
304mm	482	395	453	13m	4571712N	4571412N
355mm	533	446	504	13m	4571714N	4571414N

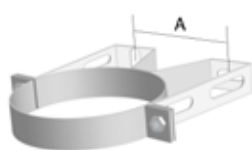
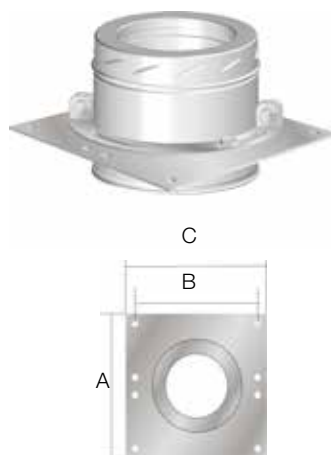

Wall Bands

Wall bands provide lateral support for the chimney and must be used at intervals not exceeding 4.0 metres beyond any load bearing support.

For external applications the stainless steel version must be used.

See page 26 for application information

Wall Band Extension Pieces

Used with Wall Bands, these components allow the clearance between the wall and outer surface of the chimney to be increased. Where externally applied, the intervals between Wall Band fixing centres must be reduced from 4.0 metres to 3.5 metres. The maximum clearance is as detailed below.

See page 26 for assembly details



∅	Dim A	Stainless Code	Galvanised Code	Extension (mm)		Stainless Code	Galvanised Code
				Min	Max		
100mm	112	3115154	3116154	65	105	3119136	3120136
130mm	142	3115185	3116185	50	100	3119136	3120136
150mm	162	3115205	3116205	50	100	3119136	3120136
180mm	192	3115234	3116234	50	100	3119136	3120136
200mm	212	3115255	3116255	50	100	3119136	3120136
250mm	266	3115305	3116305	50	100	3119180	3120180
304mm	316	3115355	3116355	75	140	3119245	3120245
355mm	366	3115405	3116405	50	120	3119245	3120245

Support Components

Nova

Pick & Mix Support System

An alternative system to SFL's conventional support components, designed to offer a flexible solution to the individual support requirements of domestic installations. Available for chimney diameters up to 250mm, each part is ordered separately to comprise the bracket required.

The Wall Band is designed to offer 50mm clearance from the outer case of the chimney to the back plate of the bracket. Where required, Extension Brackets can be used to increase this distance to within the specified dimensions as detailed within the table below. The bracket must be installed plumb and fixed to the structure using adequate fixings. The Wall Bracket is fitted with two M6 Nut Inserts to allow easy fixing of the two Support Band Rings using the M6 bolts and washers provided.

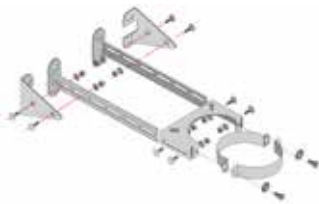

Extension Brackets are designed to extend the clearance from the outer case of the chimney to the structure. The Extension Brackets have been designed to slide through on the inside of the Wall band and can be cut to length if required.

Maximum/minimum distances for wall bands and extension arms:

∅	Max SHORT	Max MEDIUM	Max LONG	Min with Arms	Min without Extension Arms
100mm	249	320	525	55mm	50mm
130mm	234	305	510	55mm	50mm
150mm	224	295	500	55mm	50mm
180mm	209	280	485	55mm	50mm
200mm	199	270	475	55mm	50mm
250mm	174	245	450	55mm	50mm

Bracing Brackets can be attached to the Extension Brackets along with the Support Plate and Universal Split Band to produce a Wall Support for vertical loading.

∅	Maximum extension			Loading Max Loading (m)
	SHORT	MEDIUM	LONG	
100mm	124	195	400	8.6
130mm	94	165	370	7.0
150mm	74	145	350	6.2
180mm	N/A	115	320	5.2
200mm	N/A	95	300	4.8

Pick & Mix Wall Support Arrangement

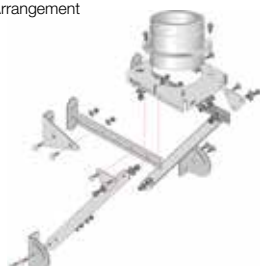

Wall Band

Can also be used as a conventional Wall Band



∅	A	Code
100mm	220	3109510
130mm	250	3109513
150mm	270	3109515
180mm	300	3109518
200mm	320	3109520
250mm	370	3109525

Extension Brackets

Available in Short, Medium and Long versions to provide the required distance from wall

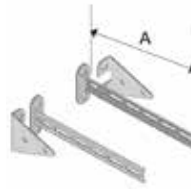

Size	A	Code
Short	324	31093ST
Medium	395	31093MD
Long	600	31093LG

Bracing Brackets

Available in three sizes to suit Extension Brackets (above).



Size	A (mm)	Code
Short	521	31094ST
Medium	557	31094MD
Long	571	31094LG

Support length

Can be used with the Support Plate and Bracing Brackets as part of a loadbearing wall support.



∅	Code
100mm	4578804N
130mm	4578805N
150mm	4578806N
180mm	4578807N
200mm	4578808N
250mm	4578810N

Support Plate

For use with the support length and cantilever framework to create a loadbearing wall support.

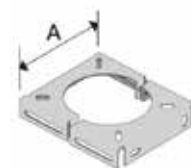

∅	A	Code
100mm	220	3109710
130mm	250	3109713
150mm	270	3109715
180mm	300	3109718
200mm	320	3109720
250mm	370	3109725





Floor & Ceiling Penetration

Nova

Gas and oil appliance (T250)

The following components MUST be used on gas or oil fired appliances where the flue gas temperatures does not exceed 250°C and / or where the chimney passes through a non-combustible floor.

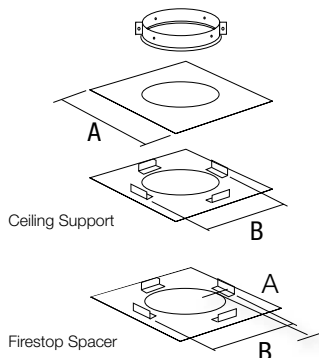

Ceiling Support

Provides a 50mm air gap clearance to a penetrated floor or ceiling and is only used where NOVA® penetrates a non-combustible floor, and / or services a gas or oil fired appliance where the flue gas temperature does not exceed 250°C

Firestop Spacer

Used to provide location, fire and dust stopping where NOVA® is used through non-combustible floors, and / or serves a gas or oil fired appliance where the flue gas temperatures does not exceed 250°C. This item does not load bear.

∅	Dimension (mm)		Code	Dimension (mm)		Code
	A	B		A	B	
100mm	300	250	4502704	300	250	4508704
130mm	330	280	4502705	330	280	4508705
150mm	355	305	4502706	355	305	4508706
180mm	381	331	4502707	381	331	4508707
200mm	406	356	4502708	406	356	4508708
250mm	457	407	4502710	457	407	4508710
304mm	507	457	4502712	507	457	4508712
355mm	558	508	4502714	558	508	4508714

Solid fuel and oil fire appliance (T450)

The following components MUST be used where NOVA® is used on solid fuel or oil fired appliances where the flue gas temperature will not exceed 450°C and / or where the chimney system penetrates a combustible floor. Each ventilated component offers a 50mm clearance to combustible materials.

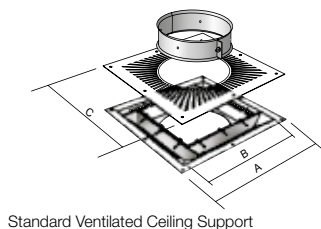

Standard Ventilated Ceiling Support

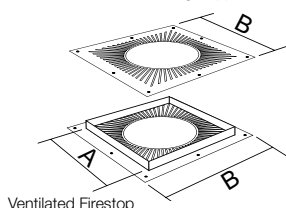

Ventilated Firestop

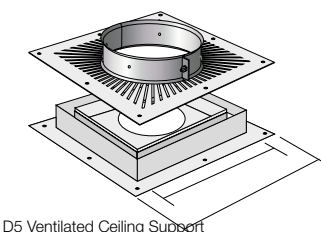

D5 Ventilated Ceiling Support

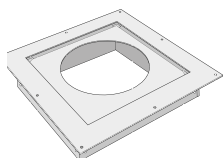

D5 Ventilated Ceiling Support Underneath View

Standard Ventilated Ceiling Support (T450)

Used to both support and firestop the chimney system when it passes through the first combustible floor directly above the appliance. The support component incorporates a patented intumescent matrix design which expands rapidly with temperature and seals the plate to prevent the potential spread of fire or smoke from the room below.

∅	Dim (mm)			Code	Dim (mm)			Code
	A	B	C		A	B	C	
100mm	331	251	349	7072710	251	349	5508310	
130mm	361	281	379	7072713	281	379	5508313	
150mm	381	301	399	7072715	301	399	5508315	
180mm	411	331	429	7072718	331	429	5508318	
200mm	431	351	453	7072720	351	453	5508320	
250mm	481	401	501	7072725	402	501	5508325	
304mm	531	451	551	7072730	452	551	5508330	

For painted variations add the following letters after the part number: - White: ZW

D5 Ventilated Ceiling Support (T450)

Used as per the standard version. The D5 offers an aesthetically pleasing flat appearance where the chimney passes through the ceiling penetration and uses minimal ventilation openings. This component is finished in a high quality white powder coated finish.

∅	A	B	Code
100mm	322	249	7072810ZW
130mm	352	279	7072813ZW
150mm	372	299	7072815ZW
180mm	402	329	7072818ZW
200mm	422	349	7072820ZW

For basic installation information concerning floor penetrations, please see page 26 of this brochure

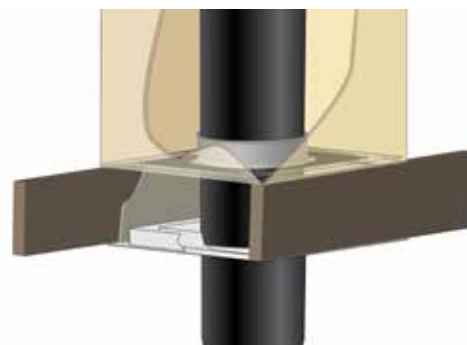

Patented Design

Domestic Gas Installation Termination Heights

Figs 5.1-5.3 (opposite) illustrate terminal siting for common installation situations for further requirements, refer to BS5440-1

No part of the flue outlet shall be less than 1.5 metres measured horizontally to the roof surface, or any wall. Where the flue terminates above the ridge, it shall do so by not less than 600mm, other than where the flue terminates with a purpose designed ridge terminal.

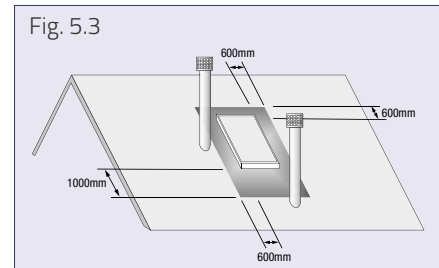
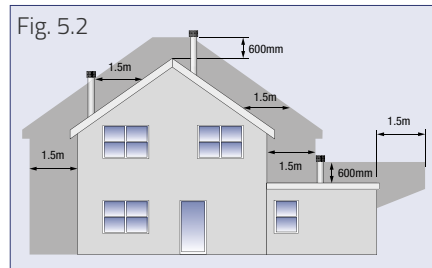
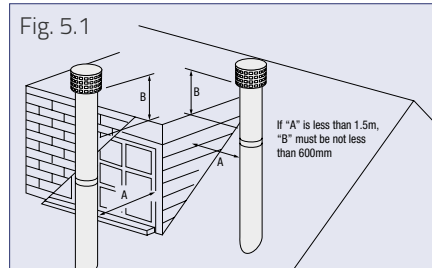

The chimney should not penetrate the dark shaded area.

Solid Fuel Chimney Termination Heights.

Chimney termination heights and positions are subject to current Building Regulations and National Standards. The illustrations are based Approved Document J of the Building Regulations for solid fuel and oil fired appliances. Domestic natural gas fired appliances are governed by BS5440-1. All other European countries are governed by their own Regulations, however reference can be made to the countries National Annex of BS EN 15287-1 for individual requirements.

If the chimney serves an oil fired appliance with a pressure jet burner, the chimney must discharge a minimum 600mm above the roof penetration point, or any adjacent structure, if it is within 750mm. It must also be at least 600mm from any opening into the building and 300mm from any combustible material.

Where used with an oil fired appliance with a vaporising burner, termination must comply with the details in this diagram

Minimum distance measured from the top of the chimney construction, excluding any pot or terminal:

- A 2.3 metres horizontally clear of the roof surface, e.g. if the roof pitch is 45°, then the chimney should project 2.3 metres above it.
- B 1.0 metre, provided A is satisfied, or 600mm above the ridge if G is less than 600mm.
- C 1.0 metre above the top of any flat roof, and the top of any openable roof light, dormer window or ventilator, etc., if it is located within 2.3 metres.
- D/E If D is less than 2.3 metres, E shall be not less than 600mm.
- F 600mm above the ridge.
- G If G is within 600mm of the ridge then B shall be 600mm above the ridge.



Gas Terminal

The Gas Terminal is available from 100mm to 355mm internal diameter.

∅	A	B	Code
100mm	236	118	4552404
130mm	236	118	4552405
150mm	267	118	4552406
180mm	293	220	4552407
200mm	320	220	4552408
250mm	368	220	4552410
304mm	421	220	4552412
355mm	469	220	4552414

Flue Outlets for Oil-Fired Appliances

Flue termination heights for oil-fired appliances must comply with BS EN 15287-1. The table below explains minimum distances in most common situations with reference to FIG. 5. For further information, please refer to the relevant National annex.

		Pressure Jet	Vapourising
B	Above the highest point at which the chimney crosses the roof	600mm	1000mm
D	From an adjacent structure	750mm	2300mm
E	Above the height of an adjacent structure at the following distances from the edge of the flue: Pressure Jet: 750mm; Vapourising: 2300mm	600mm	1000mm

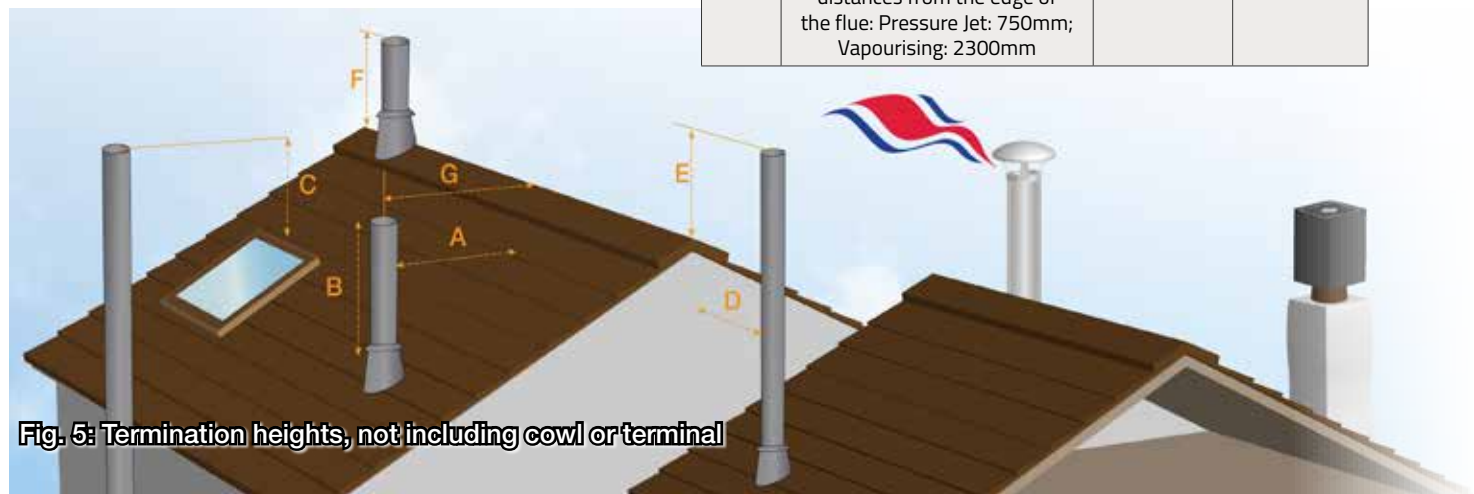
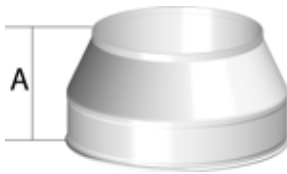

Fig. 5: Termination heights, not including cowl or terminal

Terminals

Nova



Top Stub

The terminal offers the least resistance to flue gases and is ideal for solid fuel and oil fired appliances, providing there is drainage at the base of the chimney.

Top Stub With Mesh

Ideally suited for condensing/high efficiency appliances. Not suitable for solid fuel application or where there is no provision for drainage below termination.

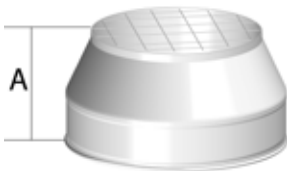

∅	Dimension (mm)		Code	Dimension (mm)		Code
	A			A		
100mm	100		4570804	100		4570704
130mm	100		4570805	100		4570705
150mm	100		4570806	100		4570706
180mm	100		4570807	100		4570707
200mm	100		4570808	100		4570708
250mm	100		4570810	100		4570710
304mm	100		4570812	100		4570712
355mm	100		4570814	100		4570714

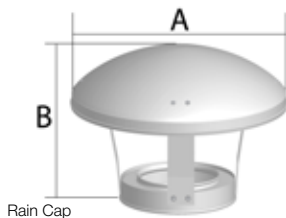

Rain Cap

The Rain Cap offers a degree of protection from rain and is suitable for solid fuel and oil fired appliances.

Round Top

The Round Top offers a greater degree of protection against driving rain and wind, recommended for exposed locations.

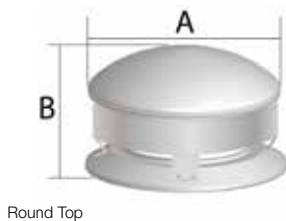

∅	Dim (mm)		Code	Dim (mm)		Code
	A	B		A	B	
100mm	255	192	4577304	255	155	4573104
130mm	255	197	4577305	300	159	4573105
150mm	300	204	4577306	300	157	4573106
180mm	358	265	4577307	358	189	4573107
200mm	402	265	4577308	402	194	4573108
250mm	500	300	4577310	500	253	4573110
304mm	716	345	4577312	614	288	4573112
355mm	716	385	4577314	716	356	4573114

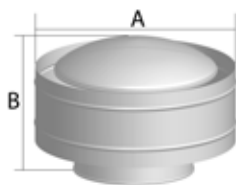

Storm Cowl

The Storm Cowl is designed to offer the maximum protection against driving rain and strong winds. Please note that this is not an anti-down draught terminal.

Storm Cowl with Mesh

Not suitable for solid fuel applications.

∅	A	B	Code	A	B	Code
100mm	270	165	4578704	270	165	4578904
130mm	294	165	4578705	294	165	4578905
150mm	319	165	4578706	319	165	4578906
180mm	344	165	4578707	344	165	4578907
200mm	369	165	4578708	369	165	4578908
250mm	419	210	4578710	419	210	4578910

Anti-Downdraught



NOVA® Mini EURO COWL

NOVA® Mini EURO COWL

The NOVA®-specific edition of the most popular anti-downdraught cowl on the market, complete with a factory-fitted NOVA female coupler and locking band for effortless and secure installation.

∅	Code
150mm	4574506N

Flashings & Weathering

Nova

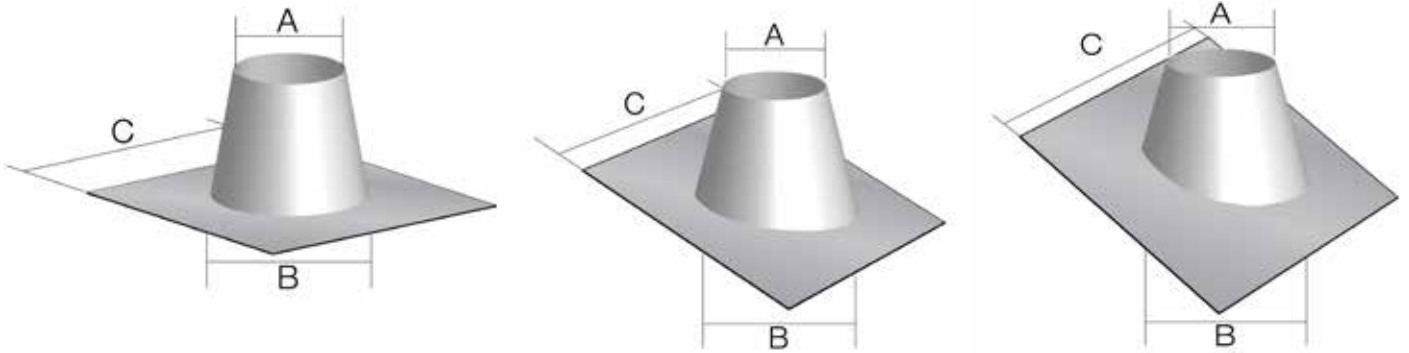

Aluminium Flashings

The SFL aluminum flashing range offers a competitive alternative to the traditional lead flashing, while still maintaining a traditional design and malleable material. All aluminum flashings require a Storm Collar (p.22).

Flat Flashing

For flat or nearly flat roofs.

5° – 30° Adjustable Flashing

For low pitched roofs.

32° – 45° Adjustable Flashing

For high pitched roofs.

ø	Dimension (mm)											
	A	B	C	Code	A	B	C	Code	A	B	C	Code
100mm	160	250	495	70000006	160	250	495	70053006	160	332	660	70324506
130mm	190	280	495	70000007	190	280	495	70053007	190	375	660	70324507
150mm	210	300	495	70000009	210	300	660	70053009	210	403	660	70324509
180mm	235	325	660	70000010	235	325	660	70053010	235	440	820	70324510
200mm	260	350	660	70000011	260	350	660	70053011	260	475	820	70324511
250mm	310	400	660	70000012	310	400	660	70053012	310	546	820	70324512
304mm	360	450	660	70000013	360	450	820	70053013	360	617	820	70324513
355mm	410	500	820	70000014	410	500	965	70053014	410	689	1219	70324514

Flashings & Weathering

Nova

In addition to the conventional range of aluminium flashings for slate roofs, SFL now offers an environmentally friendly alternative to lead flashings for use on uneven roofing materials. SFL Eco Pro Lead-free, malleable flashings feature a durable 0.6mm 304 BA stainless-steel cone, formed and adhered to the flashing base.

The flashing base can be dressed in exactly the same way as lead and is highly flexible. Craftsmen experienced in working with lead covering will find it easy to apply.

The lead-free base is highly weather resistant, completely waterproof and provides a breathable membrane which prevents the build-up of condensation. It is one third the weight of conventional lead and does not require the application of patination oil to prevent oxidation. As well as all the physical and environmental benefits, there is peace of mind that your flashing will not be the target of lead thieves and the inconvenience caused by lead theft.

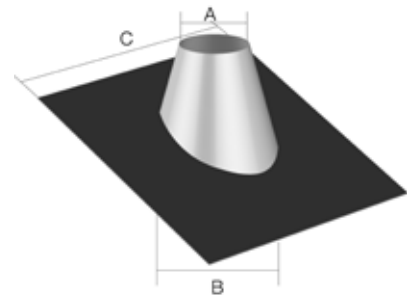
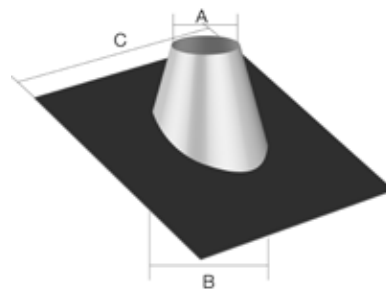

N.B. Where the lead-free base is in contact with rainwater contaminated by copper or bitumen, a protective coating will need to be applied. Please contact SFL Customer Services for details.

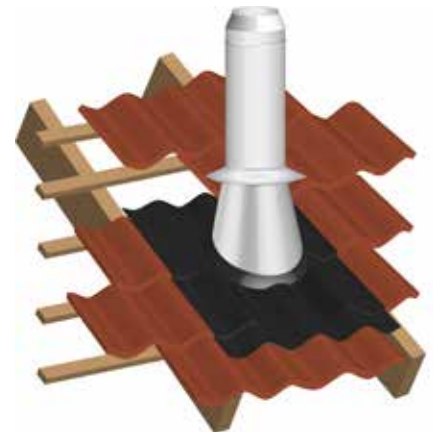

SFL EcoPro Lead-Free Flashings

5° – 30° Adjustable Flashing

For low pitched roofs.

32° – 45° Adjustable Flashing

For high pitched roofs.

∅	Dimension (mm)			Code	Dimension (mm)			Code
	A	B	C		A	B	C	
100mm	172	236	900	70053006P	160	306	900	70324506P
130mm	205	275	900	70053007P	191	350	900	70324507P
150mm	227	300	900	70053009P	211	379	900	70324509P
180mm	260	338	900	70053010P	242	425	900	70324510P
200mm	282	364	900	70053011P	263	452	900	70324511P
250mm	338	428	900	70053012P	314	524	900	70324512P
304mm	393	491	900	70053013P	365	597	900	70324513P
355mm	448	555	900	70053014P	417	669	900	70324514P

SFL EcoPro EPDM Synthetic Rubber Flashing

The selection of the correct flashing depends on the outside chimney diameter and intended roof pitch. The table identifies which flashing should be used. Each consists of a malleable aluminium base to which an EPDM rubber cone is sealed. The cone is easily trimmed on site to suit the external diameter of the chimney. Separate installation instructions are provided with every flashing.

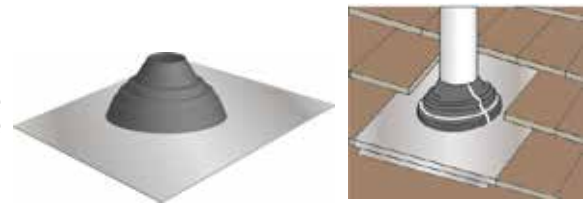

∅	Ext Dia (mm)	Roof Pitch	Flashing No.	Cone Index Cut Line	Base Size (A)	Code
100mm	150	0-35°	1	E	500X500mm	4901015
130mm	180	0-40°	2	E	600x600mm	4901020
150mm	200	0-30°	2	F	600x600mm	4901020
150mm	200	0-45°	3	C	764x764mm	4901030
180mm	230	0-40°	3	D	764x764mm	4901030
200mm	250	0-35°	3	F	764x764mm	4901030
250mm	300	0-30°	3	I	764x764mm	4901030
250mm	300	0-45°	4	A	956x956mm	4901045

The EPDM flashing system will effectively seal and remain pliant over a wide range of external chimney surface temperature extremes from -30° to 115°C. The EPDM cones have also been proven to withstand intermittent surface temperatures of up to 150°C.

EPDM flashings should not be used on single wall chimney systems serving solid fuel appliances or any application where the potential surface temperature of the chimney will exceed the maximum design temperatures details above.

Flashings & Weathering

Nova

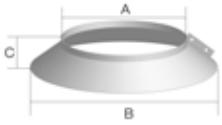

Aluminium Storm Collar

Used to weather the top of the flashing, supplied with a tube of silicon sealant.

∅	A	B	C	Code
100mm	152	255	70	70123406
130mm	177	280	70	70123407
150mm	202	301	70	70123409
180mm	227	330	70	70123410
200mm	252	351	70	70123411
250mm	302	401	70	70123412
304mm	352	451	70	70123413
355mm	402	501	70	70123414



Trim Collar

The trim collar is a polished stainless steel circular collar with a nominal 105mm wide circular flange. This item is used to offer an aesthetic closing ring where a chimney passes through an outside wall.

∅	Code
100mm	4583204
130mm	4583205
150mm	4583206
180mm	4583207
200mm	4583208
250mm	4583210
304mm	4583212
355mm	4583214

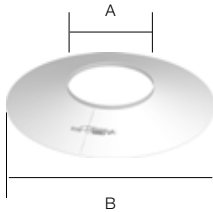

NOVA® Stainless Storm Collar

The NOVA® polished stainless steel storm collar is larger and offers a greater degree of protection from weathering. It also adds a superb looking finish to your installation. Highly recommended to complement the EcoPro flashing.

∅	A	B	Code
100mm	151	350	4504104
130mm	181	380	4504105



45° Wall Sleeves

Must be used where a 135° tee is used to pass the chimney through an external wall and thus providing a continuous interrupted run through the wall. Provides 50mm clearance as standard. Although designed to suit a 280mm maximum width wall, special sizes can be manufactured to order.

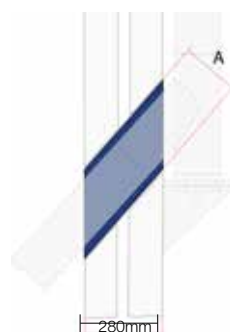

∅	A	Code
100mm	250	3107204
130mm	280	3107205
150mm	300	3107206
180mm	330	3107207
200mm	350	3107208
250mm	400	3107210
304mm	450	3107212
355mm	500	3107214

Angled Wall Cover Ring

The wall cover ring is designed to offer an aesthetic trim around the chimney where it penetrates a wall at an angle. This component is available in five angle variations, 0°-10°, 10°-20°, 20°-30°, 30°-40° and 40°-50°.

		Wall Penetration Angle				
		0°-10°	10°-20°	20°-30°	30°-40°	40°-50°
∅	A	Code	Code	Code	Code	Code
130mm	156	5571213N	5571313N	5570013N	5570313N	5570213N
150mm	146	5571215N	5571315N	5570015N	5570315N	5570215N
180mm	131	5571218N	5571318N	5570018N	5570318N	5570218N
200mm	121	5571220N	5571320N	5570020N	5570320N	5570220N



Accessories

Nova



Locking Band

The locking band must be used on all joints and are included with each component having a female coupler.

∅	Code
100mm	4578604
130mm	4578605
150mm	4578606
180mm	4578607
200mm	4578608
250mm	4578610
304mm	4578612
355mm	4578614



Joint Sealing Ring (W/P1)

This optional component is available for all diameters and is located in the joint groove as detailed in the Installation Instructions and on page 24. This component provides a moisture and gas resistant seal to a pressure of 200Pa as tested to P1 under BS EN 1856-1. The seal would normally be used on applications where there is a likelihood that condensation of the flue gases could result or where the chimney is operating under positive pressure conditions where the flue gas temperature will not exceed 200°C (T200).

Important: SFL seal lubricating compound should be applied around the surface of the seal and interfacing surface prior to making the joint. It is also recommended that the seal is carefully bonded to the fixing groove prior to installation with a suitable silicon adhesive/sealant.

∅	Code
100mm	4006310
130mm	4006313
150mm	4006315
180mm	4006318
200mm	4006320
250mm	4006325
304mm	4006430
355mm	4006435



Locking Band (Screw Toggle)

The screw-toggle locking band is provided as standard with the unbarbed female coupler on elbows and 135° tee branches.

∅	Code
100mm	4578604MT
130mm	4578605MT
150mm	4578606MT
180mm	4578607MT
200mm	4578608MT
250mm	4578610MT
304mm	4578612MT
355mm	4578614MT

Joint Sealing Ring (W/P1) for 305mm and 355mm Adjustable Lengths ONLY

These seals are to only be used for the internal slip section of the 305mm and 355mm Adjustable Lengths. All other sizes utilise the standard Joint Sealing Ring as detailed above, Part No. 40063XX in the slip section. See page 29.

∅	Code
304mm	4006530
355mm	4006535



Seal Lubricant

This must be applied around the circumference of the fitted seal to provide a lubricated interface between the seal and the liner when the product is used for positive pressure and wet applications.



Code	
250ml	3107500

Only SFL lubricant should be used as it has been specially formulated for use with both silicone and EPDM seal materials. Failure to use SFL lubricant when installing seals in NOVA product will invalidate the product warranty and potentially cause failure of the seal.

Lateral Supports

Wall Bands are available for the lateral support of the installation. These are available in both galvanised steel and stainless steel for external applications. All Wall Bands offer 50mm clearance from the outer case of the flue. Optional Extension Brackets are available to increase this distance up to a maximum of 100mm, see page 15.

Roof / Rafter Support

A roof / rafter support bracket is available where the flue section passes through the roof to termination. This component offers both lateral and vertical loading. For more information, see page 14.

Joint design and construction

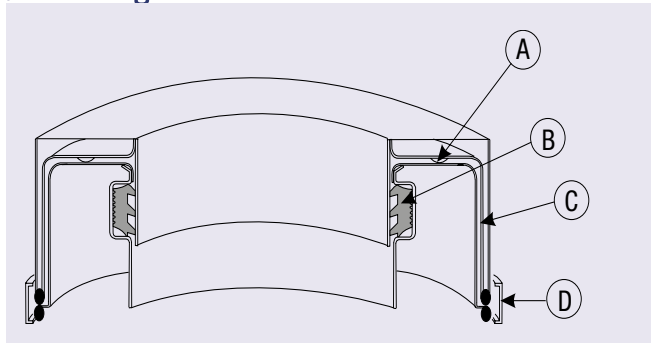

A – Coupler separator

The coupler separator is a 1mm dimple which is designed to allow a controlled amount of air to pass across the coupler interface. This limits thermal bridging and heat transfer across the joint as well as reducing the potential for capillary moisture movement.

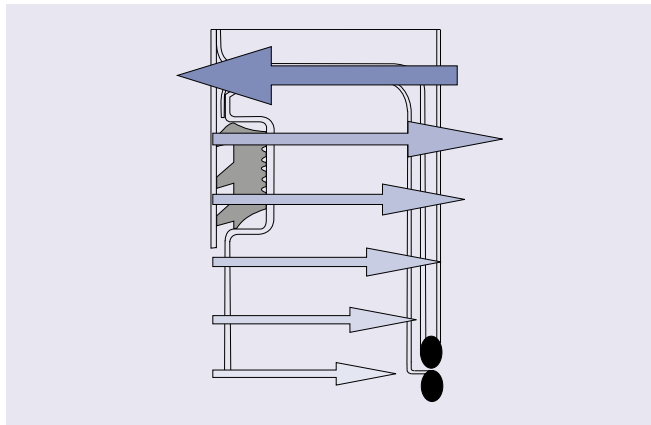

B – Retrofit seal

The NOVA® product offers a retrofit seal that can be fitted around the inner groove as shown above. The seal facilitates positive pressure and condensate resistance up to 200Pa at a maximum flue gas temperature of 200°C, offering a P1 rating to BS EN 1856-1. For higher pressure capability, please refer to SFL Technical Department.

C – Quick lock jointing system

The NOVA® joint incorporates a sixteen barb* twist lock coupler system to allow easy and rapid installation of the product. When used with the NOVA® support components the joint will support up to 3.0* metres free standing above the last support. See Installation Instructions or page 19 for further details.

* 100mm internal diameter has 8 barbs and a free standing capability of 2.0 metres, subject to design guidance.

D – Locking Band

The locking band is used to complete the joint and incorporates a simple fixing mechanism to facilitate speed and ease of installation.

Joint Assembly

The joint is made by fitting the female end over the male end and engaging the joint system by rotating the component clockwise. A locking band is then fitted to finalise the joint, as detailed below.

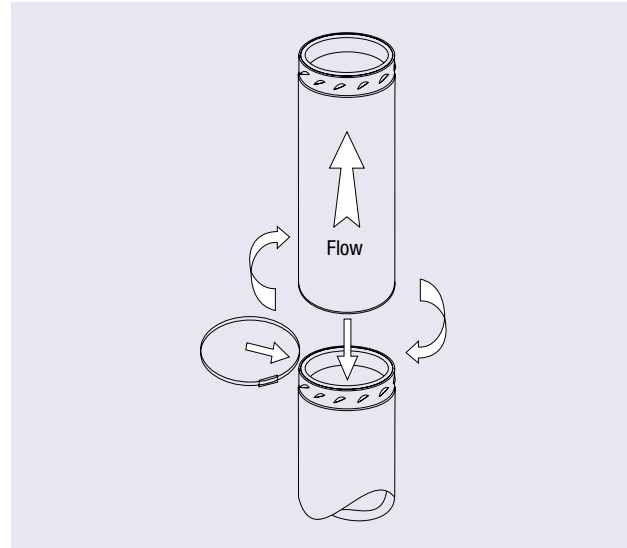

Fig. 1

Approvals

The NOVA® product has been assessed and CE marked to BS EN 1856-1 to the performance designations as detailed on page 4, Table 1.

NOVA® has also been assessed by the Loss Prevention Council for fire resistance. A fire resistance of two hours can be achieved in accordance with the stability and integrity criteria of BS 476: Part 20 for duct type B.

Quality

All components are manufactured under a quality assurance scheme, certificate No. FM557622, administered by British Standards in accordance with BS EN 9001. In addition SFL operate a CE approved factory production control system as required under the Construction Products Regulation.

Installation Regulations

Where the flue passes through combustible floors it is important that the correct firestop components are used and the correct distance to combustible materials is observed.

All firestop and support components within the NOVA® range are designed to offer a minimum clearance to combustible material of 50mm. In all instances the requirements of the building regulations must be complied with and the appropriate references are: Document J of the DOE Building Regulations, Section F of the Building Standards (Scotland), Section L of the Building Regulations (Northern Ireland). Reference should also be made to the relevant British and European Standards governing the installation of flue and chimney products for the associated fuel and appliance types as detailed:

- Solid Fuel and Oil Fired Applications: BS EN 15287
- Domestic Gas Installations up to 60kW: BS5440: Part 1
- Commercial Gas Installation up to 70kW and 1.8MW (net), the installation should conform to BS 6644

For further information, please refer to Installation Instructions in this document.

System Details

Nova

Note: In the UK, connection to an appliance which is not connected to a fuel supply, may be carried out by a competent person. However connection to an appliance that is connected to a fuel supply must be carried out by an approved and registered heating engineer, e.g. Gas Safe(Gas) or OFTEC (Oil). For other European countries, reference should be made to EN 15287: Part 1: Chimneys- Design, installation & commissioning of chimneys. Chimneys for non-room-sealed heating appliances. The National Annex NA of EN 15287 should detail the national regulatory requirements for that particular country.

Components

The NOVA® product offers a complete range of prefabricated components allowing total flexibility to meet today's demanding applications. Installed lengths of 1500mm, 1000mm, 500mm, 250mm and 120mm are available, together with adjustable lengths. A variety of tees, elbows, supports, fixings and firestop components are available as standard throughout the diameter range.

Those components within the range that are manufactured from only single skin, can be vulnerable when exposed to the products of combustion from solid fuel appliances. This is especially true for terminals; however in the majority of cases, an open-ended terminal better suits appliance performance, but it is acknowledged that on occasions, other types of terminal from the range have to be used to reduce rain entry. The condensate collector and locking plug when used on solid fuel are also vulnerable to flue gas by-products, particularly if the chimney is not regularly maintained and cleaned. Such components are considered sacrificial and their life expectancy will vary depending on application, location, maintenance and fuel usage. For this reason, these items are only covered by a twelve month guarantee and not the standard 15 year conditional manufacturing defects warranty.

Life Expectancy and Affecting Factors

The NOVA® product is manufactured to the highest standard and tested in accordance with EN 1856-1. Under normal operating conditions NOVA® should provide many years service and is provided with a 15 year conditional manufacturing defect warranty. However careful consideration of the following points must be observed to limit the risk of chemical corrosion to the product.

Chemical contamination of combustion air

Under no circumstances should an appliance be located where there is the potential of chemical contamination of the combustion air. Typical examples are de-greasing plants, dry cleaning agents and chemical cleaning products.

Chemical chimney cleaning products

Under no circumstances should chemical chimney cleaning products be used. Only traditional sweeping of the chimney should be employed.

Use only approved solid fuels

Where used on solid fuel, care should be taken to ensure that only high quality fuel is used. SFL do not recommend fuels such as petroleum coke or other fuels containing a blend of petroleum coke. Also some smokeless fuels contain halogens that are released when burnt, forming Hydrochloric and Hydrofluoric Acids. These fuels can lead to premature failure of the chimney system through corrosion. Before burning any fuel, SFL would suggest that written confirmation is obtained to ensure that the fuel is halogen free. Only HETAS Approved solid fuels should be used with SFL products.

It is also important when burning wood that it has not been treated and is free of any potential chemicals such as preservatives, insecticides or pressure treatments. Freshly cut firewood can contain up to 50% moisture, provision must be made to allow the wood to season so that the moisture content is reduced to around 20%. This must be done in a dry environment and can take up to 8 months. Green wood can lead to products like creosote being deposited on the chimney liner and could lead to a chimney fire occurring or premature corrosion / failure of the liner.

Biofuels

NOVA® is suitable for virgin pellet and wood chip biofuel applications where the fuel complies with BS EN 14961 Parts 1-6. Other forms of biofuel when burnt can produce aggressive and corrosive acids, especially at low temperatures, which can lead to premature failure of the product. Written confirmation should be obtained from SFL prior to installing NOVA® for use on any other type of biofuel.

Coastal locations

It is advised where the chimney is exposed to severe coastal locations that suitable external protection is applied to the outer case of the product. This could be achieved using a specialist protective coating or by having the product professionally painted. It is recommended that only stainless steel components are used for external applications; however where galvanised components are used, they should be adequately protected using an appropriate coating.

Typical installation serving condensing appliances

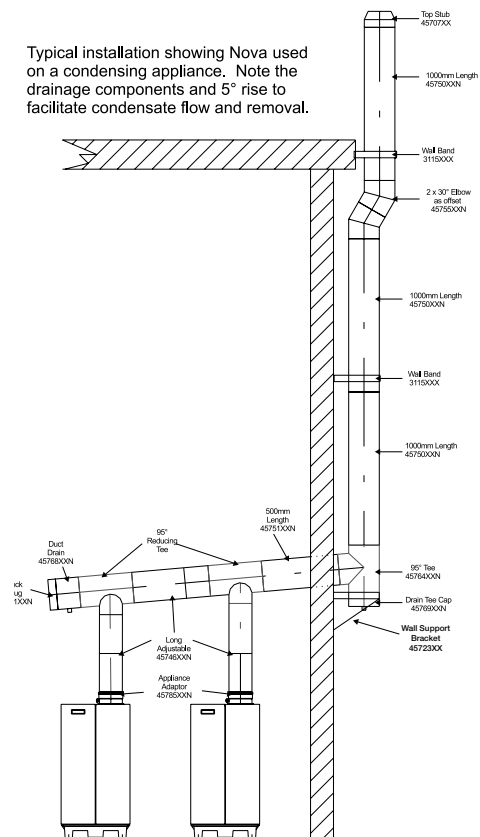

Calculation and Technical Support

Using the latest software modelling, SFL can undertake full chimney sizing calculations to BS EN 13384 Parts 1 & 2 as well as advise on other technical matters regarding the Clean Air Act and current regulations regarding chimney systems.

The illustration below shows a typical support arrangement for an external chimney. The vertical weight of the chimney is taken by a wall support bracket. A removable condensate collector (45769**) is fitted to the underside of the wall support bracket which can also be removed for sweeping. Wall bands (3115***) are then installed every 4.0 metres to provide lateral support. It is essential that adequate bracing is provided directly before and after an offset or change in direction. It is important that adequate fixings are used throughout the chimney system to anchor support components to the structure, such as M10 rawl bolts etc.

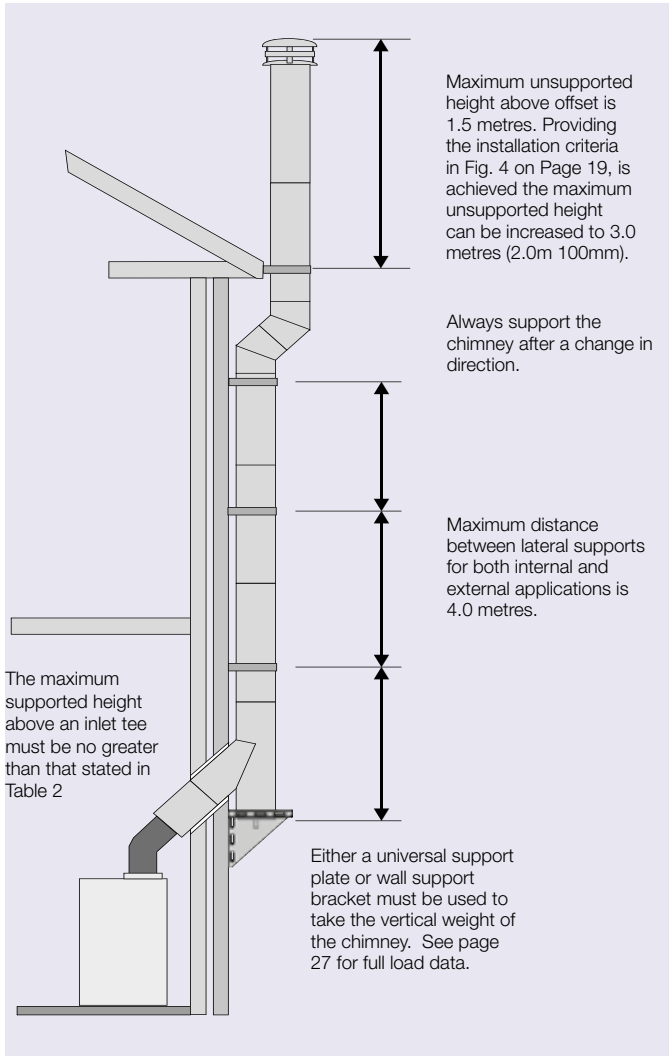

Wall Band Assembly

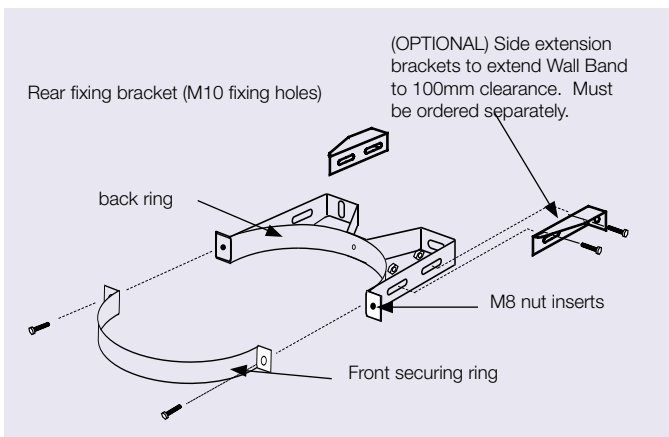

Combustible floor penetration (>250°C)

Where the chimney system is used with appliances producing flue gas temperatures exceeding 250°C, and where the chimney passes through a combustible floor, the following ventilated components MUST be used. All floor penetration components are designed to be secured to a pre-built frame construction and lined with a 30 minute fire resistant board to the dimension detailed in Table 3.

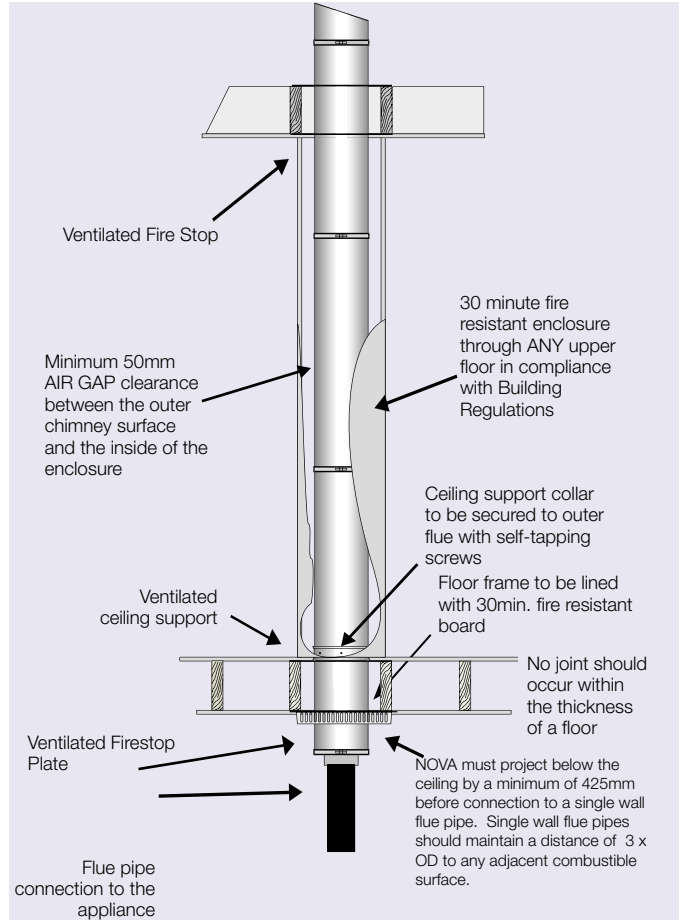

Basic installation diagram of ventilated ceiling support and ventilated firestop components

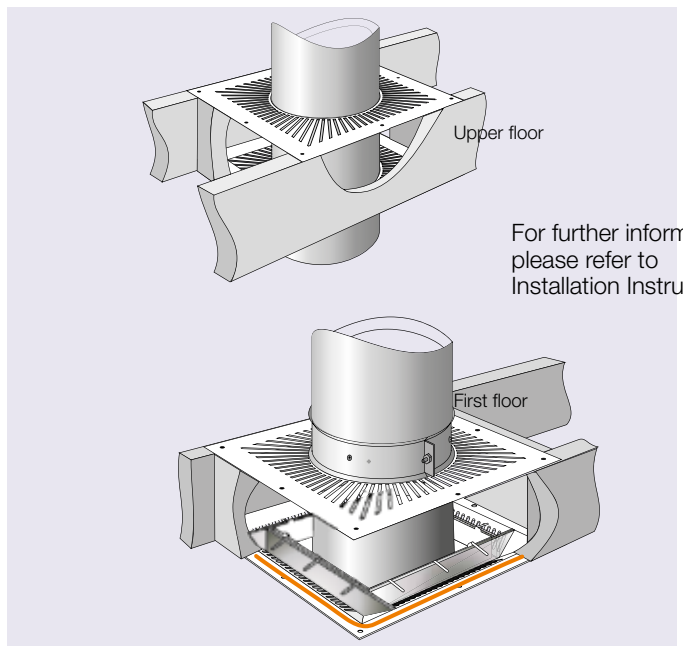

Installation

Nova

Ventilated Ceiling Support and Ventilated Firestop

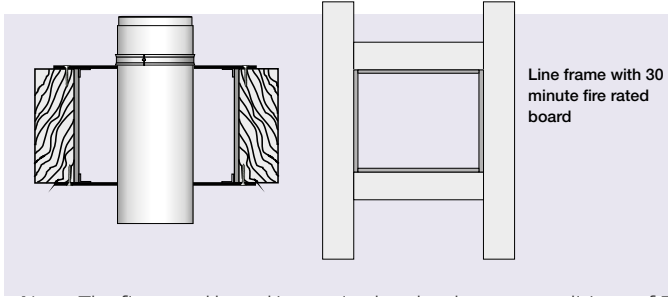

Line frame with 30 minute fire rated board

Note: The fire rated board is required under the test conditions of BS 476: Part 20 where the chimney passes through a representative combustible floor. The purpose is to protect the ceiling void from the effects of radiated heat from the outer case of the chimney where the chimney below the ceiling is engulfed in fire.

Framing data and dimensions

Chimney Size	100	130	150	180	200	250	300
'A' Square*	251	281	301	331	351	401	451

* The above dimension does not allow for 30 minute fire rated lining, adjust according to thickness used.

Elbow offset dimensions

This data relates to just two elbows used to form an offset as shown in Fig. 2. It also indicates the installed length of the elbow segments. Data is also provided where standard lengths are also incorporated within the offset, see Fig. 3.

15°	∅ (mm)	A (mm)	B (mm)	C (mm)
	100	91	358	47
130	98	385	51	
150	102	401	53	
180	108	425	56	
200	112	440	58	
250	123	484	64	
304	124	488	64	
355	134	527	69	

30°	∅ (mm)	A (mm)	B (mm)	C (mm)
	100	91	340	91
130	98	366	98	
150	102	381	102	
180	108	403	108	
200	112	418	112	
250	123	459	123	
304	124	463	124	
355	134	500	134	

40°	∅ (mm)	A (mm)	B (mm)	C (mm)
	100	91	321	117
130	98	346	126	
150	102	360	131	
180	108	381	139	
200	112	396	144	
250	123	434	158	
304	124	438	159	
355	134	473	184	

45°	∅ (mm)	A (mm)	B (mm)	C (mm)
	100	91	311	129
130	98	335	139	
150	102	348	144	
180	108	369	153	
200	112	382	158	
250	123	420	174	
304	124	423	175	
355	134	457	190	

Fig. 2

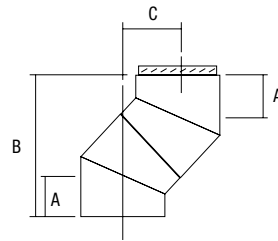
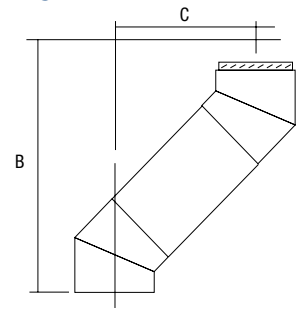

Fig. 3



Elbows are not loadbearing. Vertical runs after changes of direction should be re-supported appropriately.

∅ (mm)	120mm length							
	15°		30°		40°		45°	
	B (mm)	C (mm)	B (mm)	C (mm)	B (mm)	C (mm)	B (mm)	C (mm)
100	474	78	444	151	413	194	396	214
130	501	82	470	158	438	203	420	224
150	517	84	485	162	452	208	433	229
180	541	87	507	168	473	216	454	238
200	556	89	522	172	488	221	467	243
250	600	95	563	183	526	235	505	259
304	603	95	566	184	530	237	508	260
355	643	100	604	194	565	249	542	274

∅ (mm)	250mm length							
	15°		30°		40°		45°	
	B (mm)	C (mm)	B (mm)	C (mm)	B (mm)	C (mm)	B (mm)	C (mm)
100	599	112	556	216	513	278	487	305
130	627	115	582	223	538	287	511	315
150	643	118	597	227	551	292	525	321
180	666	121	620	233	573	299	546	330
200	682	123	634	237	587	305	559	335
250	725	129	676	248	626	319	597	351
304	729	129	679	249	629	320	600	352
355	768	134	717	259	665	333	634	366

∅ (mm)	500mm length							
	15°		30°		40°		45°	
	B (mm)	C (mm)	B (mm)	C (mm)	B (mm)	C (mm)	B (mm)	C (mm)
100	841	177	773	341	704	438	664	482
130	868	180	799	348	729	447	688	492
150	884	182	814	352	743	453	702	498
180	908	185	836	358	764	460	722	506
200	923	187	851	362	779	465	736	512
250	967	193	892	373	817	480	774	528
304	970	194	896	374	821	481	777	529
355	1010	199	933	384	856	494	811	543

∅ (mm)	1000mm length							
	15°		30°		40°		45°	
	B (mm)	C (mm)	B (mm)	C (mm)	B (mm)	C (mm)	B (mm)	C (mm)
100	1324	306	1206	591	1087	760	1018	836
130	1351	310	1232	598	1112	769	1042	846
150	1362	312	1247	602	1128	774	1055	851
180	1391	315	1269	608	1148	782	1076	860
200	1406	317	1284	612	1162	787	1089	865
250	1450	322	1325	623	1200	801	1127	881
304	1453	323	1329	624	1204	802	1130	882
355	1493	328	1366	634	1239	815	1165	897

Wall Support Bracket – technical information

Support configuration and distance between brackets

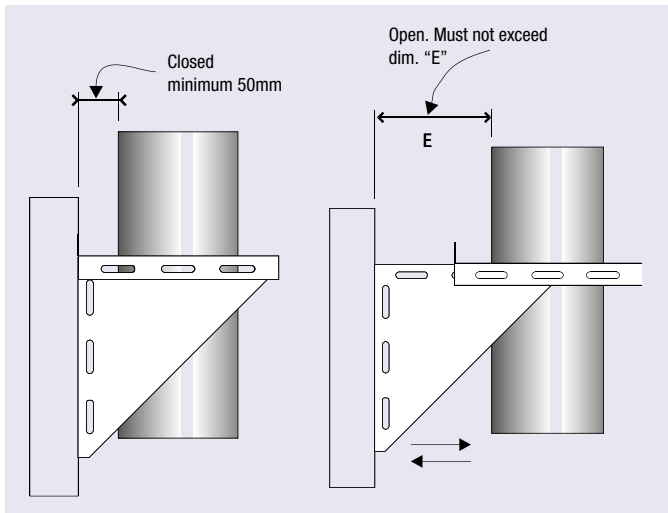

Ø (mm)	A (m)	B (m)	E (mm)
100	30	25	150
130	30	25	150
150	30	25	150
180	20	15	200
200	20	15	200
250	20	15	220
304	20	15	267
355	18	12	293

This table details the maximum distance in metres between wall supports, based on the support configuration below.

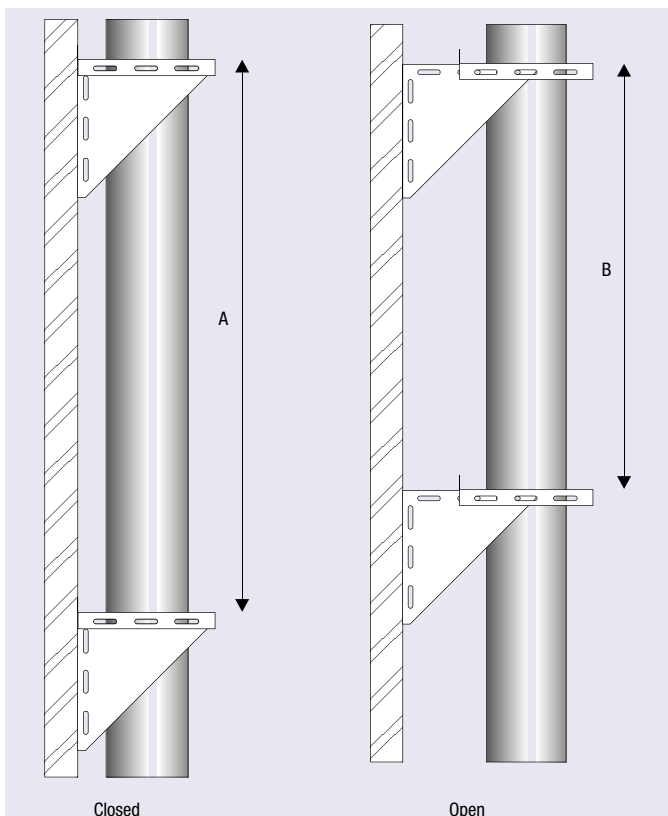

IMPORTANT: Wall support loadings are dependent on appropriate wall fixings and the structural integrity of the wall itself.

Product weights

Maximum weight of NOVA® per metre run installed, excluding support components.

Ø (mm)	100	130	150	180	200	250	304	355
kg/m	6.6	8.1	9.2	10.8	11.8	14.5	17.1	19.7

Maximum structural considerations for components

The table below shows the maximum number of metres that can be applied to various components. It is essential that these are not exceeded. Where possible components such as inlet tees and inspection lengths should not be vertically loaded, but suspended below a support component, such as the wall support assembly. Where this is unavoidable, refer to the maximum heights in the table below.

Table 2

Components	Diameter (mm)							
	100	130	150	180	200	250	304	355
Inspection length	13m	13m	13m	13m	13m	13m	13m	12m
Ceiling support	6m	6m	6m	6m	6m	6m	6m	6m
Ventilated ceiling support	6m	6m	6m	6m	6m	6m	6m	6m
Anchor plate	13m	13m	13m	13m	13m	13m	13m	13m
Universal support plate	13m	13m	13m	13m	13m	13m	13m	13m
95° & 90° tee	13m	13m	13m	13m	13m	13m	13m	13m

Adjustable Slip-Length with Cover Jacket

Component extension limits above an existing length

Dia Ø	Combined adjustment range on standard lengths							
	Extension		250mm		500mm		1000mm	
	Min	Max	Min	Max	Min	Max	Min	Max
80	48	295	375	545	550	795	1050	1295
100	48	295	375	545	550	795	1050	1295
130	48	295	375	545	550	795	1050	1295
150	48	295	375	545	550	795	1050	1295
180	48	280	375	530	550	780	1050	1280
200	48	270	375	520	550	770	1050	1270
250	48	245	375	495	550	745	1050	1245

N.B. The Adjustable Slip Length requires a standard length to make a complete component. Adjustable lengths are not loadbearing. A support component should be used immediately above.

Installation

Nova

Detailed installation instructions are provided with all adaptors and terminals, and are also available separately on request, detailed below are key installation requirements for the NOVA® chimney system together with regulatory requirements for the UK. For countries outside of the UK, please refer to your country's own regulations and national standards.

General

The installation of the NOVA® product must be in accordance with local building regulations and associated National Standards and Codes of Practice.

For additional guidance, reference can be made to BS EN 15287-1: Chimneys- Design, installation & commissioning of chimneys. Chimneys for non-room-sealed heating appliances The National Annex NA of EN 15287-1 will detail the national requirements for the particular country.

Every chimney section and fitting shall be used as manufactured for assembly on site without any alteration or cutting. Components are joined with a multi barbed twist lock coupler and secured with a locking band. The only exception are elbows, which are designed to allow full rotation of the component and therefore do not have locking barbs on the female end. All components must be installed with the male coupler facing up as detailed in Fig.1 on Page 24.

NOVA® is suitable for both internal and external applications. Where used on high efficiency condensing appliances, a range of components are available to permit deliberate drainage of condensate, either back to the condensate removal component within the chimney system, or through the heating appliance. No part of the chimney system should be constructed to form an angle greater than 45° from the vertical.

Although components are included that will permit horizontal application, they should only be used for connection to the appliance. Where the system is being used for a condensing application, sections MUST run at an angle not less than 3° - 5° from the horizontal, using tees, elbows and fittings designed for that purpose. Failure to provide adequate drainage could lead to premature failure of the product and seal.

Offsets can be constructed using elbows, lengths and adjustable components available within the system. For full details regarding offset dimensions and heights for various elbow/length combinations see tables on Page 27. According to building regulations: If bends are necessary there must be no more than four in the length of the chimney. The angle of the bend should be no greater than 45° from the vertical, with the exception that 90° factory made bends or tees may be treated as being equal to two 45° bends.

Where an offset is used, the length of chimney between the two elbows MUST NOT exceed 20% of the total vertical length of the chimney.

Where serving solid fuel or oil appliances, any part of the chimney which passes through any room other than that in which the appliance using the chimney is situated, should be protected to prevent damage and accidental location of combustible material against the outer skin. It is a building regulation requirement that ANY factory made insulated chimney should be enclosed where passing through a cupboard, storage space or accessible roof space.

Where used with solid fuel or oil appliances producing flue gas temperatures exceeding 250°C, the clearance at floor / ceiling joists must be established using the ventilated ceiling support and ventilated firestop components. When connecting to a single wall connecting flue or vitreous pipe, at least 425mm of NOVA® must project below the appliance room ceiling before connection is made.

Under no circumstances must there be a joint within the thickness of any floor space. Where passing through a cavity wall a wall sleeve must be used and finished with a suitable trim plate / cover ring.

The internal diameter of the chimney must conform to the requirements of the appliance manufacturers instructions and should not, under any circumstances, be less than the diameter of the appliance outlet unless operational requirements of the appliance can be demonstrated by calculations to BS EN 13384-1

The height of the chimney will depend on the building structure, however a height of 4.5 metres from the top of the appliance outlet to termination is considered the minimum for solid fuel. To prevent excessive cooling of the flue gases when connecting a single wall flue pipe from the stove to the NOVA® chimney, SFL recommends that the length of the single wall pipe is no more than 2.0 metres within the 4.5 metre height recommendation under Building Regulations.

Adjustable Lengths

Each Adjustable Length is supplied in two halves together with an insulation pack. When required for positive pressure or wet systems, two seals are required in addition to the Adjustable Length. Fit and lubricate seals as show in the diagram below. Depending on the required finished length of the component, additional insulation is added to the annulus of the top section. The top section is then slid over the bottom section and the component installed. Self-tapping screws are then used to secure the overlapping sections.

The Adjustable Length does NOT load bear. Always use a Wall Support Assembly or Support Plate immediately above this component when vertically applied. Adjustable Lengths should maintain a clearance of at least 300mm to combustible materials.

Please note that the design of the 300ID and 350ID Adjustable Length is different to the 100ID to 250ID as detailed in the diagrams below.

100ID - 250ID Adjustable Length seal position (Suitable for gas and kerosene oil)

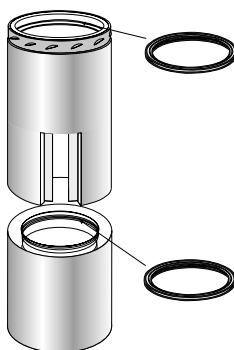

Where condensate and pressure resistance is required, the 100ID to 250ID Adjustable Length requires two standard seals fitted in both the top and bottom sections of the component as detailed opposite. Ensure that the seal is well lubricated and the interfacing materials are clean and free of dirt prior to assembly.

304ID - 355ID Adjustable Length seal position (Suitable for gas only)

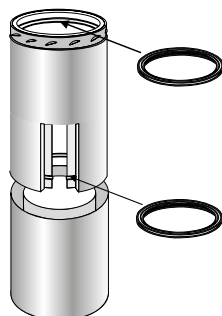

Where condensate and pressure resistance is required two different seals need to be fitted to the upper section. Unlike the 100ID - 250ID, no seal is required in the bottom section. The top seal is located in the groove inside the throat of the male coupler. The bottom seal is stretched over the circumference of the liner and located in the groove. Ensure that the seal is well lubricated and the interfacing materials are clean and free of dirt prior to assembly.

Installation criteria for maximum freestanding height

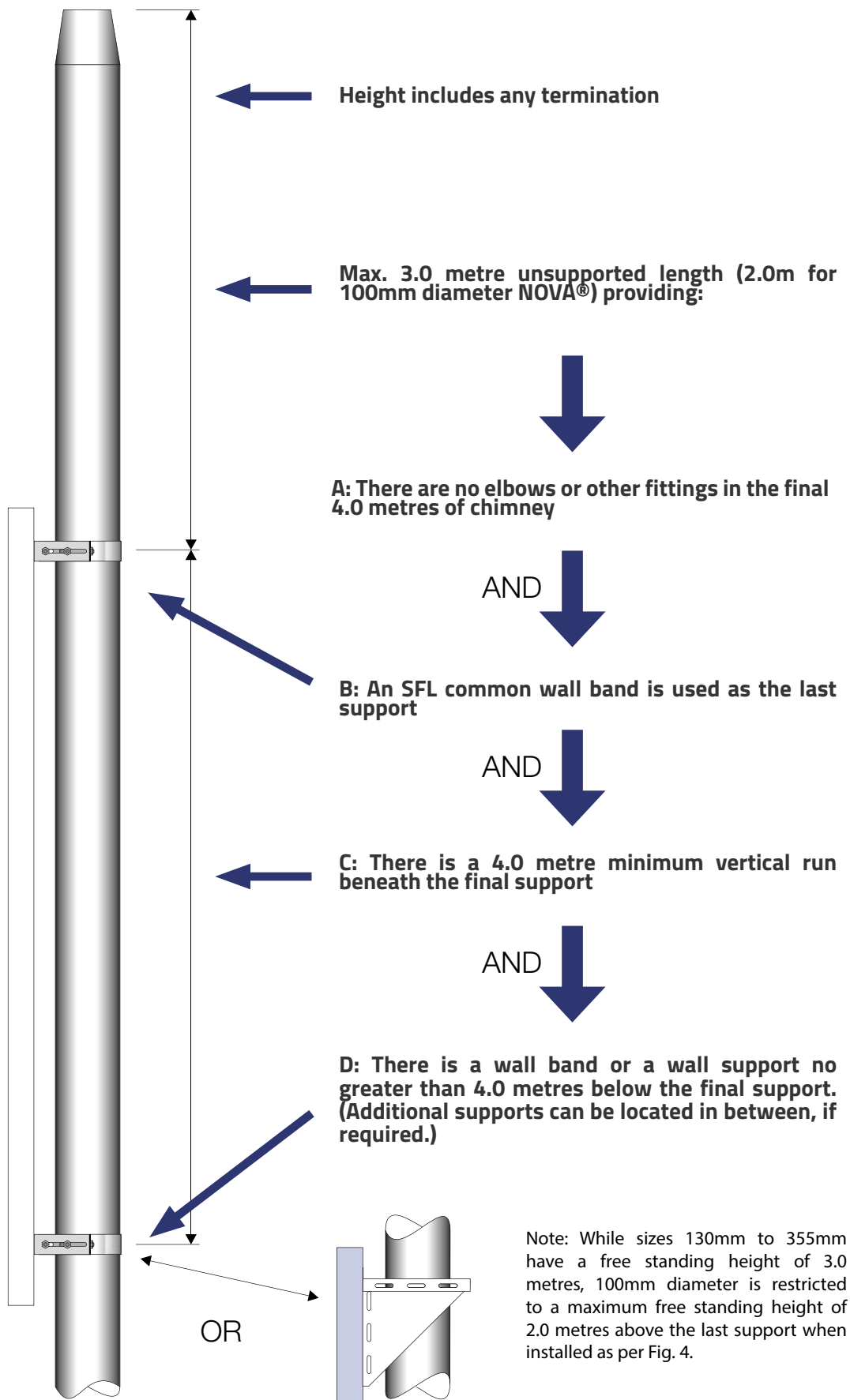

Fig. 4 Maximum unsupported termination detail

About Us

Since 1969 we have provided expertise in system design and innovation for commercial, domestic and industrial applications, with uncompromised customer service. Our portfolio of trusted brands are known throughout the world for their engineering excellence.

We are proud of our British built heritage at SFL. All our products are fabricated at our manufacturing centre in Barnstaple, Devon, UK. As well as investment in the latest manufacturing system, we also have an extensive R&D centre ensuring continuous product development and testing to the latest European Standards.

Our Brands

SFL branded products are synonymous with the highest quality – it is this reputation that enables specifiers, contractors and house-holders to use our products with total confidence.

NOVA

SUPRA

EUROPA

SIGMA

S-FLUE

IL

**TUBEX
PLUS**

Get in touch

Head Office & Manufacturing Facility

SFL Flues & Chimneys
Pottington Business Park
Barnstaple
Devon
EX31 1LZ

Tel: +44 (0) 1271 326633
Email: info@sflchimneys.com
Web: www.sflchimneys.com



SFL pursues a policy of continuous improvement in both design and performance of its products and therefore reserves the right to change, amend or vary specifications without notice. Whilst the details contained herein are believed to be correct they do not form the basis of any contract and interested parties should contact the Company to confirm whether any material alterations have been made since publication of this brochure.